

Received July 23, 2020, accepted August 3, 2020, date of publication August 6, 2020, date of current version August 20, 2020.

Digital Object Identifier 10.1109/ACCESS.2020.3014732

Comprehensive Review on Detection and Classification of Power Quality Disturbances in Utility Grid With Renewable Energy Penetration

GAJENDRA SINGH CHAWDA¹, (Graduate Student Member, IEEE),
ABDUL GAFOOR SHAIK¹, (Member, IEEE), **MAHMOOD SHAIK¹**, (Graduate Student Member, IEEE), **SANJEEVIKUMAR PADMANABAN²**, (Senior Member, IEEE),
JENS BO HOLM-NIELSEN², **OM PRAKASH MAHELA³**, (Senior Member, IEEE), AND
PALANISAMY KALIANNAN⁴, (Senior Member, IEEE)

¹Department of Electrical Engineering, IIT Jodhpur, Jodhpur 342037, India

²Department of Energy Technology, Aalborg University, 6700 Esbjerg, Denmark

³Power System Planning Division, Rajasthan Rajya Vidyut Prasaran Nigam Ltd., Jaipur 302005, India

⁴School of Electrical Engineering, VIT University, Vellore 632014, India

Corresponding authors: Gajendra Singh Chawda (chawda.1@iitj.ac.in) and Sanjeevikumar Padmanaban (san@et.aau.dk)

This project was carried out under the Project No. 19-MG04AAU, Danida Mobility Grant, responsible for the Ministry of Foreign Affairs of Denmark (MFA), Act 7 on Denmark's International Development Cooperation and Visvesvaraya PhD Scheme, MeitY, India, under Project AKT/2014/0030.

ABSTRACT The global concern with power quality is increasing due to the penetration of renewable energy (RE) sources to cater the energy demands and meet de-carbonization targets. Power quality (PQ) disturbances are found to be more predominant with RE penetration due to the variable outputs and interfacing converters. There is a need to recognize and mitigate PQ disturbances to supply clean power to the consumer. This article presents a critical review of techniques used for detection and classification PQ disturbances in the utility grid with renewable energy penetration. The broad perspective of this review paper is to provide various concepts utilized for extraction of the features to detect and classify the PQ disturbances even in the noisy environment. More than 220 research publications have been critically reviewed, classified and listed for quick reference of the engineers, scientists and academicians working in the power quality area.

INDEX TERMS Artificial intelligence, power quality disturbances, international standards of power quality monitoring, signal processing, renewable energy sources, noise.

ABBREVIATIONS

ACO	Ant colony optimization	FAM	Fuzzy associative memory
ADC	Analog to digital converter	FANN	Fuzzy-ARTMAP neural network
AI	Artificial intelligence	FC	Fundamental component
ANN	Artificial neural network	FCM	Fuzzy C-Means
BC	Bayesian classifier	FES	Fuzzy expert system
BCO	Bee colony optimization	FIR-DGT	Finite Impulse Response Window
DAQ	Data acquisition system	FPGA	Field programmable gate array
DAGSVM	Directed acyclic graph SVM	FSCL	Frequency sensitive competitive learning
DB4W	Daubechies 4 wavelet	FT	Fourier transform
DRST	Double resolution S-transform	GA	Genetic algorithm
DSP	Digital signal processing	GMOCUW	Generalized morphological open-closing and close-opening undecimated wavelet
DT	Decision tree	GST	Generalized S-transform
EC	Energy content	GT	Gabor transform
		HC	Hybrid classifiers

The associate editor coordinating the review of this manuscript and approving it for publication was Elisabetta Tedeschi¹.

HHT	Hilbert-huang transform
HOS	Higher order statistics
HST	Hyperbolic ST
IA	Instantaneous amplitude
ICA	Independent component analysis
KF	Kalman filter
KMC	Kurtosis of magnitude contour
KPC	Kurtosis of phase contour
LSSVM	Least square SVMs
LVQ	Learning vector quantization
MGW	Morphological gradient wavelet
MIST	Modified incomplete ST
MM	Mathematical morphology
MOT	Miscellaneous optimization techniques
MPNN	Modular probabilistic neural network
NFS	Neuro fuzzy system
POI	Point of interconnection
PSO	Particle swarm optimization
PQDs	Power quality disturbances
RES	Renewable energy sources
RMS	Root mean square
RTDS	Real time digital simulation
SCICA	Single channel ICA
SFS	Sequential forward selection
SMC	Skewness of magnitude contour
SOPC	System on programmable chip
SP	Signal processing
SPC	Skewness of phase contour
SSD	Sparse signal decomposition
ST	Stockwell transform
STD	Standard deviation
STFT	Short time FT
SVM	Support vector machine
THD	Total harmonic distortion
TTT	Time-time transform
T2FK-SVM	Type-2 Fuzzy Kernel-SVM
WPE	Wavelet packet entropy
WT	Wavelet transform
ZC	Zero crossings

NOMENCLATURE

α	Scale parameter of the wavelet function
\hat{x}_k	Current state estimate
$\omega(\tau, d)$	Scaled replica of the fundamental mother wavelet
τ	Translation parameter of the wavelet function
$f(n)$	One-dimension signal with domain $D[f] \subset E$
$F(s)$	Fourier transform for any function of $f(x)$
$g(n)$	Structure element with domain $D[g] \subset E$
$g(t)$	Window function
h	Mother wavelet
K_k	Kalman gain
$S(\tau, \omega)$	Gabor transform signal
$w_j(t)$	Instantaneous angle frequency
$WT(\alpha, \tau)$	Wavelet function
$X(t)$	Real part in HHT

I. INTRODUCTION

In recent years, the proliferation of the grid integrated renewable energy (RE) sources are increasing in the low and medium voltage utility grids to meet the energy demand. Renewable energy sources in the utility grid require power electronic-based converters which not only provide interfacing between these sources and utility grid but also allow higher levels of penetration [1]. The higher level of RE penetration largely affects the power quality (PQ). It may lead to various PQ disturbances such as excess reactive power, transients, power factor collapse, large current and voltage fluctuations, sag, swell, notch, harmonics, and noise, etc. [2]. These power quality disturbances are also generated in the utility grid due to sudden load changes, switching of lines, non-linear loads, faults, and strength of the ac grid. Power quality disturbances (PQDs), as mentioned above, are considered as the leading cause of deterioration of quality of power. These, result in malfunctioning of digital equipment, unwanted tripping of protective relays and circuit breakers, damaging of computer and microprocessor-based sensitive devices. Therefore, it is essential to diagnose these PQDs according to international standards, and suitable preventive techniques should be implemented. In this regard, detection and classification of features are the essential tasks of PQ monitoring systems in smart grid [3]. In a PQ monitoring system, a set of features are optimized, and the best feature for the detection and classification process is selected to make the analysis more effective. The most desired features in smart grid monitoring and operation are fast response and adaptation of detection and classification techniques with the changes associated with renewable energy penetration, noise and loads. Hence, the researchers are focused on the advancement of signal processing based detection techniques and artificial intelligence-based classification techniques for smart utility grids, which promises an effective solution to the monitoring of PQ challenges in the smart grid [4]. The methods resulted in fast and accurate detection and classification of PQDs in the utility grid with RE penetration. The attractive features of these techniques are simple structure, fast convergence, ease of calculation and minimum error. These techniques have been successfully validated in the hardware, real-time and online framework using hardware-based controllers such as DSP, FPGA, etc. It also has been recognized that the modern improvement in artificial intelligence-based algorithms and Deep-learning based algorithms have added to the extension of computer vision and image recognition ideas. Image recognition is the process of recognizing and detecting an object or a feature in a digital image or video. This idea can be applied to various systems like automation, monitoring, and defence surveillance. The literature on image recognition establish that the feature extraction efficiency has been enhanced significantly compared with the conventional methods. Consequently, the study has made a beneficial investigation for the application of image enhancement methods in PQD identification [5]. The real power quality signals are converted into gray images, and three image enhancement

techniques are employed, namely the gamma correction, edge detection and peaks and valley detection. They are used for several classes of disturbances to magnify the gray image features, which is very helpful for PQ recognition [6]. On this foundation, the disturbance features are separated, and the original feature set is regained. The new scheme can remove disturbance features altogether, and has more eminent signal processing performance compared with conventional ST and EMD methods [7]. Hence, these image recognition methods have been observed as another possible solution for PQ monitoring with RE integration. And it can also be a focused area in upcoming days due to smooth visualization, novelty and providing facilities with a technical computing environment for data analysis.

There are few reviews available on power quality assessment and monitoring. Authors have thoroughly analyzed the previously published review articles. Lieberman *et al.* [8] emphasized on power quality disturbance classification and presented the characteristics of PQ events. Saini and Kapoor [9] showed a comprehensive study of SP techniques used for PQ monitoring. Mahela *et al.* [10] presented various detection and classification techniques and the effect of noise on PQ events diagnosis. Avdakovic *et al.* [11] have emphasized on feature extraction techniques and WT applications for the analysis of the power system dynamic performance. Khokhar *et al.* [12] presented state of the art on applications of DSP based techniques and optimization techniques in the classification of PQDs. Augustine *et al.* [13] emphasized on wavelet-based PQ detection techniques by simulating and detecting the events with various types of wavelets. Best wavelet selection for a particular type of event is explained with comparisons. Shashank *et al.* [14] present an account of major computational intelligence-based techniques for addressing the problem of islanding in power grids with renewable energy penetration. Also, a comprehensive review of machine learning-based algorithms has been discussed in [15] for addressing effective decision making and control actions capabilities. Emerging PQ challenges due to renewable energy penetration with control algorithms have been addressed in [16]. However, early monitoring of these PQ challenges with RE sources paves a new future research path. Investigation in the selection of generalized methodology for detection and classification of single and multiple PQDs with RE penetration is a significant focus area nowadays and needs more considerable attention. The motivation of this article is to present a comprehensive review of detection and classification techniques for PQDs with RES in the utility grid. The existing research on PQ detection and classification would provide a strong foundation for addressing PQ challenges in the utility grid with RES. Therefore the research articles based on experimental and simulation studies are collected. This review provides an opportunity to faculty, engineers, and utility/industrial personnel to know the latest development, PQ diagnosis-related issues and to overcome them with possible areas of research through outcomes of this review.

Over 220 publications [1]–[222] are critically reviewed in this manuscript and it comprises six sections. Section 1 introduces multiple aspects of power quality disturbances monitoring under introduction. Section 2 covers the general concept of power quality disturbances with RE penetration and international guidelines to monitor these disturbances. Section 3 described the methodology for PQ monitoring with the integration of RE sources, its techniques for detection and classifications with considering the effect of noise. Section 4 depicts the experimental system-based analysis of multifarious SP based detection and AI-based classification techniques with RE penetration and their technical descriptions. Key findings and recommendations for future research work are presented in Sections 5. Finally, the conclusion is drawn in Section 6.

II. POWER QUALITY DISTURBANCES AND INTERNATIONAL STANDARDS

Electric power quality (PQ) refers to the ability of smart electrical equipment to consume the electric power being supplied to it and maintain voltage within the acceptable range. PQ disturbances and their international standards are discussed in the following subsections.

A. POWER QUALITY DISTURBANCES

The PQ disturbances can be defined as any deviation in voltage, current and frequency quantities from acceptable range which may result in mal-operation and failure of smart electric equipment. These cause sudden changes in the supply voltage, connected loads and pure sinusoidal quantities [17]. The significant issues regarding primary effects on PQ during power quality disturbances include voltage sag or voltage dip, voltage swell, voltage spikes, voltage fluctuations, harmonics distortion, voltage unbalance, over-voltage, under-voltage, power frequency variations, very short and long interruptions. Also, renewable energy integration into the utility grid would further worsen the PQ because of the unpredictable nature of the RE sources [18] and FACTS based inverters used for their interfacing with the network. Hence, RE integration performance is largely affected by [19]. The specific PQDs associated with RES operating conditions like grid synchronization, outages, islanding, variations of solar insolation and wind speed variations are well researched in [20]–[23] which have to be detected and classified accurately. These are summarized as following:

1) GRID SYNCHRONIZATION OF RES

The grid synchronization of RES generates PQDs like voltage sag or voltage dips predominantly. During the grid synchronization, a sudden decrease in voltage occurs termed as voltage dips. The limiting dip value is less than 3%. It is caused by the inrush current produced due to small inevitable differences between the voltage of solar PV and grid in the case of solar energy penetration. In the case of WE, the reactive power drawn by DFIG causes voltage sags. In the case of hybrid RES sources, voltage swell is followed by voltage

sag. Also, voltage rise occurs at the point of interconnection due to the tripping of loads, the phase angle ϕ and line impedances X-R ratios. Flickers, impulsive transients, high magnitude oscillatory transients, low magnitude harmonics are also reported. The frequency deviation increases with the penetration level of RES but is less for solar when compared to WE source.

2) OUTAGE OF RES

The outage of RES is associated with voltage variations like swell and sag. The Outage of solar RES does not produce a flicker but has an impulsive transient and frequency variations associated with it. Similar disturbances are found in the case of wind and hybrid RES. The frequency drop is directly proportional to the penetration level of RES. Thus, frequency variations can be observed easily when a large outage occurs. Also, the frequency variation is less for WE when compared to solar RES. Low magnitude oscillatory transients are also reported for all the types of RES.

3) ISLANDING OF RES

Islanding causes specific PQDs like voltage sags, swells and low magnitude impulsive transients for solar RES, wind and hybrid sources. Oscillatory transients PQ disturbances are not reported significantly for islanding with RE sources, and it requires more focus. This event is also associated with a sudden increase in the frequency, unlike outage or grid synchronization. The frequency jump is more in the case of either solar or wind when compared to islanding of sources simultaneously.

4) VARIATION OF SOLAR INSOLATION

A decrease in solar insolation creates voltage sag. The voltage fluctuations are also observed with variations in the voltage magnitude. These also indicate the presence of low magnitude flicker in the voltage with low magnitude transients. Due to sudden change in the solar insolation, frequency deviations occur, current and voltage harmonics increase with an increase in the penetration level of solar PV energy.

5) VARIATION OF WIND SPEED

Wind speed variations also cause voltage fluctuations which in turn produced a low magnitude flicker. The transient magnitude, frequency deviation, current and voltage harmonics significantly increases, when WE penetration increases. The voltage variations, ripples also indicate the presence of low magnitude flicker in the voltage in the case of variation of wind speed as well as solar irradiation changes.

These PQDs, and the sources of disturbances like the operating conditions of RES along with power system faults if not detected and mitigated quickly might cause the failure of the end-use equipment and also power system assets [24]–[27]. Hence, IEEE has laid down the guidelines, which is measured based on the above mentioned PQ distortions in the utility grid with RE penetration [28]. These PQDs majorly influence the performance of the RE sources during grid

TABLE 1. Important international standard of PQ monitoring [32].

Org.	Standards	Illustration
IEEE	519-2014	Guidelines for harmonics control of electrical PQ
	1159-1995	Guidelines for monitoring of electrical PQ issues
	1100-1999	Guidelines for powering and grounding of sensitive equipments
	1250-1995	Guidelines for service to sensitive equipment from momentary voltage disturbances
IEC	1366-2012	Guidelines for electric power utility indices
	P1547	Guidelines for interconnecting DG/RES in utility network
	61000-2-2	Guidelines for maintaining compatibility with low frequency disturbances in utility network
	61000-2-4	Guidelines for compatibility level in industrial plants for low frequency disturbances
	61000-4-7	Guidelines for non-linear distortion in utility network
	61000-4-15	Guidelines for measurement of voltage flicker
EN	61000-4-30	Guidelines for minimum accuracy for measurement of different electrical parameters
	50160:1999	Guidelines for voltage characteristics of utility network

operating conditions causing voltage and frequency instability at POI and hence, restrict the RE penetration level into the utility grid. Therefore, researchers should reconsider or modify the PQD monitoring techniques in the presence of RE sources. Presently, mathematical, simulation and hardware languages such as C, matrix laboratory (MATLAB), electromagnetic transient design and control (EMTDC), Power system computer-aided design (PSCAD), and very high speed integrated circuit hardware description language (VHDL) are generally employed for parametric synthesis based generation of PQ disturbances [29]–[31]. Hence, PQ recognition with new PQ monitoring techniques is a significant focus area for smart grids with RE penetration.

B. INTERNATIONAL STANDARDS OF POWER QUALITY

International standards are essential to provide guidelines for the manufacturers and PQ monitoring community. Power quality standards laid by the Institute of Electrical and Electronics Engineers (IEEE), International Electrotechnical Commission (IEC) and European Committee for Electrotechnical Standardization (CENELEC) are globally acknowledged and accepted. Global bodies have to continuously coordinate with each other to standardize the PQ disturbances [33], [34]. IEC 61000 and EN 50160 are the generally applicable standards for PQ disturbances [32], [35]. However, the new perspective of RE Grid Codes is discussed in [36]. These standards address various PQ disturbances and are illustrated in Table 1.

III. POWER QUALITY MONITORING METHODOLOGY

The procedure involved in PQ monitoring with RE sources is as illustrated in Fig. 1. Power quality disturbances are originated at the point of interconnection, where the conventional generator and renewable energy sources are integrated with distribution loads. Disturbance detection and classification stages are the main components of PQ recognition methods, and RE sources signals need to be considered for adopting changes associated with the output of RE sources. For this regard, the power quality monitoring process involved

different stages. In the pre-processing stage, PQ disturbances are normalized and fed to the feature extraction stage. Here the signal processing (SP) based techniques are used to extract features to detect the disturbances, and a threshold is set for accurate detection. These features are also used for the optimization and optimized features will be selected for the classification purpose. In the classification stage, AI-based classifiers are used to classify the PQ disturbances by setting an appropriate threshold. These classified disturbances are later mitigated in the mitigation stage using distributed flexible AC transmission system (DFACTS) devices [37]. Distributed FACTS devices play a significant role in the field of PQ mitigation in real-time [38]. The PQ mitigation techniques with RE penetration are a potential future academic research area and need more attention [39].

A. SIGNAL PROCESSING BASED FEATURE EXTRACTION TECHNIQUES

Power quality disturbances can be measured using deviations in frequency, variations in grid voltage, transient, the occurrence of flickers, and harmonics, to name a few. The adoption of the proper features of PQDs is crucial for the detection process. These features may directly be extracted from the initial measurement in any transformed domain or the parameters of signal models. The categorization of various detection techniques is as illustrated in Fig. 2. This section covers the new advancements concerning feature extraction techniques in the subsequent subsections.

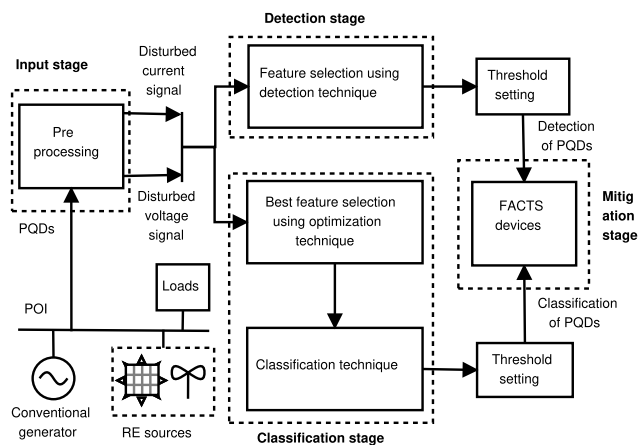

FIGURE 1. Procedure of power quality monitoring with RE sources.

1) FOURIER TRANSFORM BASED PQDs DETECTION TECHNIQUE

Fourier Transform (FT) has proved itself as a magical mathematical tool that breaks a function or signal into an alternate representation, characterized by sine and cosines [40]. This is of great help for the power system engineers to solve detection problems most efficiently. For any function $f(x)$, the Fourier Transform is denoted as $F(s)$, where the outcome of x and s is dimensionless. However, x is a measure of

time in the time-domain signal, and s corresponds to inverse time or frequency in the frequency domain signal.

$$F(s) = \int_{-\infty}^{\infty} f(x)e^{-2\pi isx} dx \quad (1)$$

$$f(x) = \int_{-\infty}^{\infty} F(s)e^{2\pi isx} ds \quad (2)$$

In both cases, $i = \sqrt{-1}$. Researchers proposed different ways of FT synthesis as well as online monitoring for better feature extraction. This includes online [41], real-time [42] and experimental [43] framework for the selection of small window size with the help of FT to provide automated detection of PQDs. Characterization of oscillatory transients using FT has been discussed in [44]. In [45], authors examined the methods of PQ detection in the frequency domain, mainly the FT, WT, HHT, S-transform with a micro-grid and universal waveshape-based method [46] has been presented for the better signal monitoring of PQDs. Feed-forward STFT has been developed efficiently for detecting PQ events reported in [47]. Also, fractional Fourier transform as a generalized version of FT has been presented in [48]. The hybrid FT and WT have also been used for detection as well as classification of the PQDs.

2) KALMAN FILTER BASED PQDs DETECTION TECHNIQUE

GF Welch and G Bishop gave the modern definition of Kalman Filter (KF) [49]. It is a set of scientific equations that affords a practical computational means to determine the state of a process, in a design that reduces the mean of the squared error. In this filter, the information in the past states is stored and used for calculating the subsequent states. The current estimation is calculated based on the preceding state information using the following equation.

$$\hat{x}_k = K_k Z_k (1 - K_k) \hat{x}_{(k-1)} \quad (3)$$

where, \hat{x}_k = current state estimate, K = discrete time intervals, $k = 1$ can be taken as 1 ms & $k = 2$ as 2ms, Z_k = measurement value, K_k = kalman gain, $\hat{x}_{(k-1)}$ = previous state signal. Kalman gains (K_k) is the unknown component of the given equation. This gain is calculated based on the measured values, and the preceding estimated signal. Combined KF and the fuzzy expert system has been proposed in [50] for minimizing the issues of tuning and tracking of harmonic fluctuations in the Kalman filter. Extended Kalman filtering is a non-linear filtering algorithm which has been found to be an efficient technique for the detection, localization, and classification of PQDs in the utility grid [51]. Its complex domain version named as an extended complex Kalman filter is designed along with an estimator based on a feed-forward NN structure to elaborate PQDs for accurate detection in [52]. Maiden application of a variant of KF algorithm known as local ensemble transform-based KF for power system harmonic estimation is presented in [53]. Detection of grid fundamental voltage and harmonic components using a modified Kalman filter [54] for renewable energy penetration has been presented in [55].

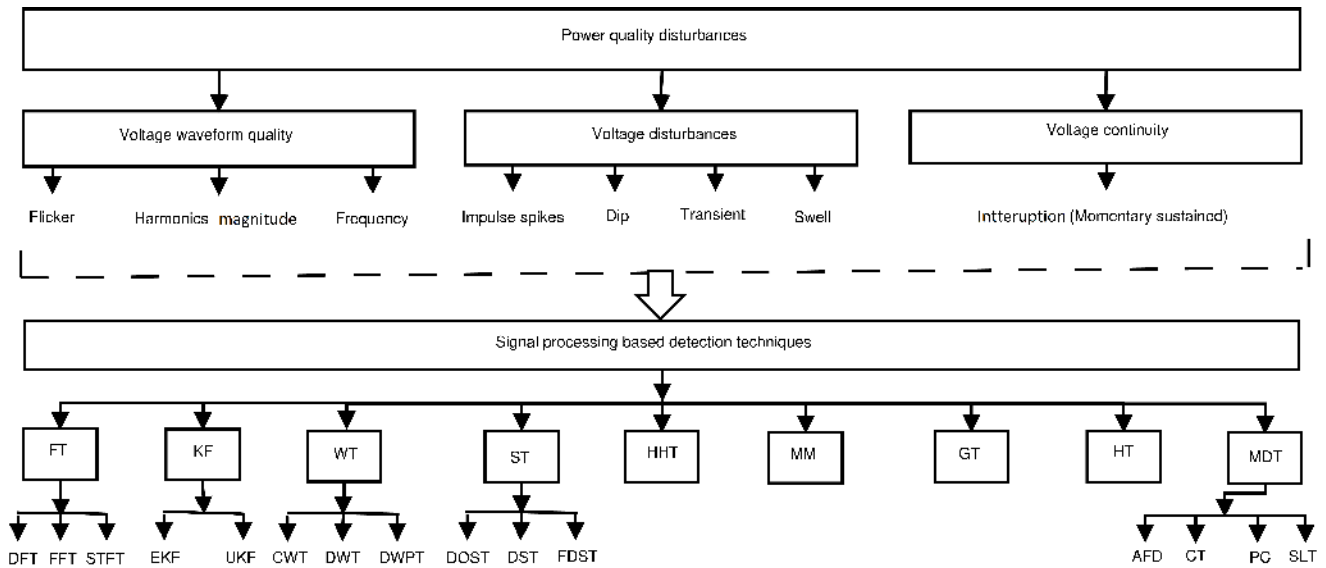

FIGURE 2. Categorization of SP based detection techniques.

3) WAVELET TRANSFORM-BASED PQDs DETECTION TECHNIQUE

Wavelet transform (WT) is similar to the Fourier transform (FT) with a different merit function. The main difference is that FT decomposes the signal into sine and cosine functions, i.e., the function is localized in the Fourier space, whereas WT uses functions that are localized in both the real and Fourier space which can be expressed as,

$$WT(\alpha, \tau) = \int_{-\infty}^{\infty} h_{\alpha, \tau}^*(t) s(t) dt \quad (4)$$

$$h_{\alpha, \tau}^*(t) = \alpha^{-1/2} h\left(\frac{t - \tau}{\alpha}\right) \quad (5)$$

The wavelet function $h_{\alpha, \tau}^*(t)$ and the signal $s(t)$ is the inner product of the complex conjugate and it is represented as $WT(\alpha, \tau)$. The Wavelet function $h_{\alpha, \tau}^*(t)$ is proportional to the reciprocal of the frequency. Where, variable α , τ and h are represented as scale parameter, translation parameter, and mother wavelet respectively. In the wavelet network, combined ability of WT, SVM for analyzing non-stationary in [56] and for multiple signals in [57] have been presented in a real-time environment. The other WT based detection techniques include, interpolated DFT [58], actual data based noise-suppression method using WT and un-decimated WT [59], integrated rule-based approach of DWT-FFT [60], DTCWT and sparse presentation classifier (SRC) [61], combine wavelet packet and t-sallis entropy [62], empirical-WT based time-frequency technique [63], rank wavelet support vector machine (rank-WSVM) [64], wavelet packet decomposition (WPD) [65], combination of WT and SVM [66], WPE and MIST [67], hybridization of daubechies wavelets db2 and db8 [68], multi-flicker source power network using WT [69], variants of WT, namely the maximum overlapping DWT and the second-generation WT [70], threshold selection using WT [71], maximal overlap discrete wavelet transform

[72], DB4 wavelet [73], dual-tree complex wavelet-based algorithm [74] and harmonic evolution [75]. Power quality disturbances detection using DWT in the utility network with wind energy penetration has been presented in [76]. Table 2 illustrated the performance analysis of the wavelet family and provided a quick overview. The performance of the wavelet family transforms for PQ detection has been decided and implemented by the comparison of the multiple attributes used by the researchers in current research [11]. These attributes of the wavelet family transform are beneficial for knowing the performance level in the detection of PQ disturbances. However, Daubechies is found best suitable wavelet for detection of PQ disturbances due to its attracting features like,

- The Daubechies wavelet has compact support and orthogonal ability with coefficient scaling facility. Hence it is found best for PQ disturbances feature analysis.
- It has been recognized that, during RE penetration into the utility grid, frequency issues significantly occurred and Daubechies wavelet can provide balanced frequency responses during PQDs detection.
- Daubechies wavelets utilise overlapping windows, so the high-frequency coefficient spectrum indicates all high-frequency variations. Consequently, Daubechies wavelets are beneficial in compression and noise elimination of PQDs.
- This overlap enables the Daubechies D4 algorithm to pick up the desired feature compared to other conventional wavelet algorithms.

4) STOCKWELL TRANSFORM BASED PQDs DETECTION TECHNIQUE

Stockwell transform (ST) is an extended idea of the continuous wavelet transform (CWT). In other words, a modified

TABLE 2. Performance evolution of wavelet family [11].

Attributes	Wavelet family							
	A	B	C	D	E	F	G	H
Compact supported	Yes	Yes	Yes	Yes	No	No	No	No
Orthogonal scaling	Yes	Yes	Yes	Yes	Yes	No	No	No
Reconstruction	Yes	Yes	Yes	Yes	No	No	No	No
Robust algorithm	Yes	Yes	Yes	Yes	No	No	No	No
Ease of application	Yes	Yes	Yes	Yes	No	M	No	Yes
Flexibility	Yes	Yes	Yes	Yes	No	M	No	M
Scaling function	Exit	Exit	Exit	Exit	Exit	NA	NA	NA

*Haar-A, Daubechies-B, Symmlets-C, Coiflet-D, Meyer-E, Gaussian-F, Mexican hat-G, Morlet-H, Marginally-M.

wavelet transform is known as S-transform and used as a time-frequency spectral localization method. The $CWT(\tau, d)$ is a scaled replica of the fundamental mother wavelet, and it is defined as,

$$CWT(\tau, d) = \int_{-\infty}^{\infty} h(t)\omega(t - \tau, d)dt \quad (6)$$

The dilation d determines the width of the wavelet $\omega(\tau, d)$ and therefore controls the resolution. The key features of this unique transform are the frequency-dependent resolution of the time-frequency space with absolutely referenced local phase information [77]. The ST is expressed as,

$$ST(t, f) = \int_{-\infty}^{\infty} h(t) \left(\frac{|f|}{\sqrt{2\pi}} \right) e^{\left(\frac{-(t-\tau)^2 f^2}{2} \right)} e^{-j2\pi ft} dt \quad (7)$$

$$g(t) = \left(\frac{1}{\sigma\sqrt{2\pi}} \right) e^{\left(\frac{-t^2}{2\sigma^2} \right)} \quad (8)$$

$$\sigma(f) = \left(\frac{1}{|f|} \right) \quad (9)$$

where, $h(t)$, $g(t)$ and $\sigma(f)$ are the signal, scalable window and control parameters of the Gaussian window respectively. ST offers superior frequency solution for lower frequency and for higher frequency better time-frequency solution. This is found as a best detection technique in a noisy environment [78]. The other S-transform reported in the literature includes, discrete orthogonal S-transform [79], hybrid S-transform [80], generalized hyperbolic ST [81], Modified ST with random forest tree [82], ST and DT [83], Multi-resolution S transform (MST) [84], discrete ST [85], ST-extreme learning machine (ELM) [86], rule-based ST [87] and experimental validation of non-stationary signal parameters under the spectrum leakage using nonergodic S-transform (NEST) [88]. Recognition and assessment of various factors associated with wind turbines [89] and hybrid Solar Photo-Voltaic (SPV), Fuel Cell (FC), and Wind Energy (WE) penetration have been presented in [90]. Also, power quality monitoring in distribution networks with WE penetration using S-transform has been presented in [20].

5) HILBERT-HUANG TRANSFORM-BASED PQDs DETECTION TECHNIQUE

Hilbert-Huang transform (HHT) is one of the best SP based techniques for time-domain analysis of non-linear and

non-stationary PQD signals. HHT obtains instantaneous frequency data by decomposing a signal into intrinsic mode functions (IMF). It has found an effective technique and can extract the IMF components of a signal. Then Hilbert transform has been applied on IMF to obtain the instantaneous frequency and amplitude with the many applications. The original data can be expressed using the Hilbert spectrum analysis. It is used to compute the instantaneous frequency of the signal and represented as the real part in the following form,

$$X(t) = Real \sum_{j=1}^n a_j(t) e^{i \int w_j(t) dt} \quad (10)$$

where $w_j(t)$ denotes the instantaneous angle frequency. For better performance in power quality application, many researchers presented different HT based detection techniques in simulation as well as hardware framework for multiple PQDs in the utility grid. This includes, an improved HHT [91] for analysis of time-varying waveform, combination of EMD and HT form HHT [92], smart sensor based on HHT [93], symbolic aggregate approximation (SAX) [94], ensemble empirical mode decomposition (EEMD) [95], HT and fuzzy based intelligent classifier [96], HHT for composite power quality events [97]. Automatic PQ events recognition using HHT and improved HHT have been presented in [98]–[100]. An islanding event has been accurately detected using HHT with wind energy [101] and PQ disturbances detected in the presence of distributed generation [102].

6) GABOR TRANSFORM BASED PQDs DETECTION TECHNIQUE

Dennis Gabor proposed a special case of STFT, formulates into the Gabor transform (GT). This transform is beneficial as the phase content of the local divisions and sinusoidal frequency of a signal. It can also be determined with its change over time. GT signal $S(\tau, \omega)$ is expressed as,

$$S(\tau, \omega) = \int_{-\infty}^{\infty} f(t)g(t - \tau)e^{-j\omega t} dt \quad (11)$$

where, the amount of the time shift is represented by τ and window function represented by $g(t)$. The center μ_t and radius Δ_t are individually calculated as follows,

$$\mu(t) = \frac{\int_{-\infty}^{\infty} t \times |g(t)|^2 dt}{\int_{-\infty}^{\infty} |g(t)|^2 dt} \quad (12)$$

$$\Delta(t) = \sqrt{\frac{\int_{-\infty}^{\infty} (t - \mu_t)^2 \times |g(t)|^2 dt}{\int_{-\infty}^{\infty} |g(t)|^2 dt}} \quad (13)$$

The width of the window function is equal to $2\Delta_t$ and interval range span from $\mu_t - \Delta_t$ to $\mu_t + \Delta_t$. Size and location of the window function and the harmonic trends of $f(t)$ can closely be observed in [103]. Gabor Wigner transforms (GWT) based on fractional Fourier transform has been proposed in [104]. This algorithm can improve the time-frequency investigation problem in the presence of low signal

to noise ratio. Gabor transforms integrated by a PNN model to implement a pattern recognition system and illustrated attractive features like multi-resolution and multi-orientation [105]. Also, the real-time feasibility of GT has been investigated by developing a laboratory-based hardware system [106]. In this system, nine types of different PQDs have been successfully detected and evaluated for illustrating the performance efficacy of the algorithm.

7) MATHEMATICAL MORPHOLOGY BASED PQDs DETECTION TECHNIQUE

Mathematical Morphology (MM) was developed in 1964 by the collaborative work of George Matheson and Jean Serra. Presently, many researchers are focusing on the MM because of less computational time and highest efficiency for detection. In this technique dilation and erosion has been considered for fundamental operator and operation is based on the addition or subtraction to $f(n)$ and $g(n)$ in an M -length mobile window. These operators are further utilized to extract the desired features [107].

$$\text{dilation} : (f \oplus g)(n) = \max\{f(n-m) + g(m)\} \quad (14)$$

$$\text{erosion} (f \ominus g)(n) = \min\{f(n+m) - g(m)\} \quad (15)$$

where, the range for dilation is $m = 0, M-1, n = 0, N+M-2$ and the range for erosion is $m = 0, 1, M-1, n = 0, N-M-1$, domain: $D[f] \subset E$ with one dimensional signal is represented by $f(n)$ and the domain: $D[g] \subset E$ with structure element is denoted by $g(n)$. Any two combination of fundamental operations can generate many operations,

$$\text{Open operator} (f \circ g) = (f \ominus g) \oplus g \quad (16)$$

$$\text{Close operator} (f \bullet g) = (f \oplus g) \ominus g \quad (17)$$

$$\text{Open - close operator} OC(f) = f \circ g \bullet g \quad (18)$$

$$\text{Close - open operator} CO(f) = f \bullet g \circ g \quad (19)$$

The open circle is represented by \circ (opening) and close circle is represented by \bullet (closing). The opening of f by g is obtained by the erosion of f by g , followed by dilation of the resulting by g . Similarly, the closing of f by g is obtained by the dilation of f by g , followed by the erosion of the resulting structure by g . After calculating the fundamental operators by MM, it was imported in the power system for extracting desired features. Morphological gradient wavelet, MM, and digital filtering with some basic terminology and mathematical description have been discussed in [108]. However, [109]–[112] articles concluded that there are no clear guidelines for selection of the structuring element for a specific application for a specific field. An advanced MM technique for PQDs detection has been introduced for less computational time and better efficiency than other PQDs detection techniques in [113]. In [114], authors presented great accuracy and fast convergence for a wide range of different operational conditions involving transitory events of frequency deviation, amplitude variations, signal phase shifts, and stable power swings. Whereas, a new morphological filter for DFIG wind

farm based microgrid has been proposed in [115]. Morphological pattern spectrum (MPS) and PNN is proposed in [116]. In [117] authors proposed novel method morphology singular entropy (MSE), which consists of three techniques, i.e., MM, singular value decomposition (SVD) and entropy theory. Monitoring of voltage variations using MM operation in real time scenario as per the IEEE Std. 1159 has been presented in [118], [119]. PQ disturbances detection in the distribution grid with wind energy penetration using MM has been presented in [120].

8) MISCELLANEOUS PQDs DETECTION TECHNIQUES

Apart from the algorithms discussed in the preceding section, some new SP based techniques have performed a vital role in PQDs detection in the last two decades. These includes, advanced DSP techniques [121], [122], slant-transform (SLT) [123], improved chirplet transform (ICT) [124], amplitude and frequency demodulation (AFD) technique [125], higher-order statistics (HOS) [126] and HOS with case-based reasoning [127], time–time transform (TTT) [128], principal curves (PC) [129], DWT and IDWT [130], sequence components of voltages are measured in presence of solar PV using FFT [131], sparse signal decomposition on hybrid dictionaries reduced [132], kernel extreme learning machine technique [133], double resolution ST (DRST) [134], DWT, multi-resolution analysis, and the concept of signal energy [135], phase-locked loop (PLL) and symmetrical components [136], Reduced sample Hilbert–Huang transform (RSHTT) [137]. However, time-frequency based ST is found superior to STFT and WT [138]. DWT and multiple signal classification (MUSIC) combined to estimate frequency and amplitude in the presence of solar PV energy [139]. Table 3 presents a performance analysis of different signal processing techniques, taking into consideration their efficiency of operation for PQ detection in the real-time scenario. The performance of the different signal processing techniques for PQ detection has been decided and implemented by the comparison of the multiple properties of majorly implemented SP based transforms used by the researchers in current research. These properties of SP based STFT, WT, ST and modified ST are beneficial for knowing the performance level in the detection of PQDs and hardware design. However, ST and its modified versions are found best suitable for detection of PQ disturbances.

B. ARTIFICIAL INTELLIGENCE-BASED PQDs CLASSIFICATION TECHNIQUES

The categorization of AI-based classification techniques is illustrated in Fig. 3. Artificial Intelligence-based classification techniques are used for categorizing PQD signals in two or more types according to their features. The essential steps for strong disturbance characterization include defining and extracting good-quality features. Disturbance characterization is still a focus research area for many researchers. This section deals with the processes involved in the classification of PQDs. This process includes two steps: the classifier utilizes optimal feature extraction of the acquired signal by

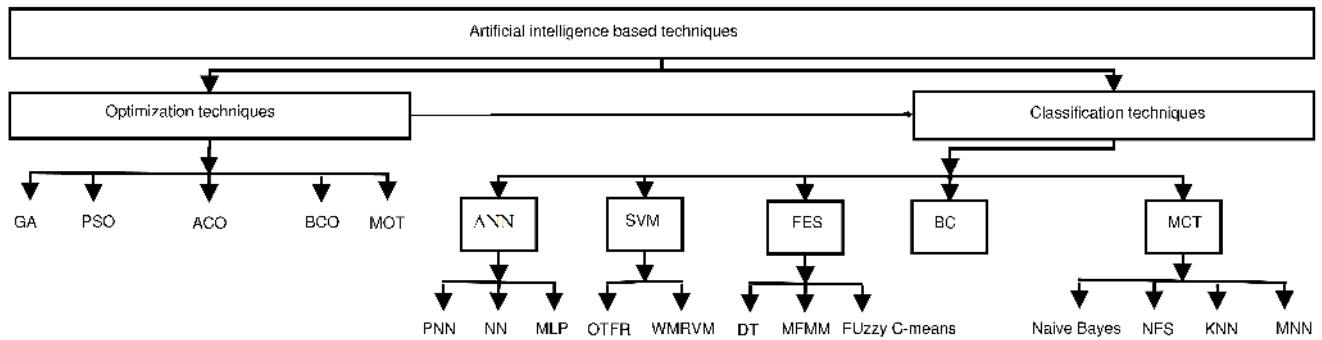

FIGURE 3. Categorization of AI based classification techniques.

TABLE 3. Performance analysis of different signal processing techniques.

Properties	STFT	WT	ST	Modified ST
Window size	Fixed	Changeable window (small to large)	Adjustable (dependent on input samples)	Easily adjustable (dependent on input samples)
Magnitude, time and frequency measurement	Possible	Possible	Possible (where scale S-matrix and mesh plots)	Perfectly possible (Where scale is s-matrix)
Frequency accuracy	Not accurate (Fixed window)	Not accurate	Accurate	Most accurate
Execution of results in different software	Easy (Window size selection is more important)	Little difficult (Requires suitable AI based techniques)	Little difficult (Visual inception can be acquired using right technique)	Little difficult (Requires suitable AI based techniques)
Frequency and time resolution	Marginally good	Good (Usage large windows for low frequency and small window for high frequencies)	Better time and frequency resolution compared to others	Better time and frequency resolution compared to ST
Industrial real-time implementation	Marginally possible	Possible with less accuracy	Possible with accuracy	Possible with accuracy
Robustness	Poor	Good	Very good	Excellent
Computational complexity	Complex	Marginally complex	Less complex	Less complex than ST
Flexibility	Not flexible with all types of signals	Marginally flexible with all types of signals	Flexible with all types of signals	Flexible with all types of signals
Signals corrupted by noise	Fail	Affected	Not affected	Not affected
Non-stationary signals	Fail	Affected	Not affected	Not affected
Applicability with hardware/real time implementation with RE sources	Poor	Good	Very Good	Excellent

optimization techniques, and these features for accurate classification. The classification process may change depending on the type of algorithm and application. These steps are highlighted in the following subsections.

1) OPTIMIZATION TECHNIQUES FOR OPTIMAL FEATURES SELECTION

Features (SD, Min-max amplitude, harmonics, entropy, RMS values, etc.) can lead to the optimization and identification of the type of disturbances. The optimization techniques are used to select the optimal features for accurate classification. These include GA, PSO, ACO, and BCO, and they are best-suited optimization techniques for PQDs classification in the utility network. Figure 4 shows the general framework of optimal feature selection for classification of PQDs. In this framework, the collected PQDs information is directly fed into the learning algorithm for the best feature selection for the optimization. Further, optimized features help classifier for classifications of the PQDs. Note: the selection of optimal

features and classification efficiency of PQDs may vary with the type of algorithm.

a: GENETIC ALGORITHM-BASED OPTIMIZATION TECHNIQUES

Genetic algorithm is a method of “reproduction” computer programs, developed by Prof. John Holland in the 1960s.

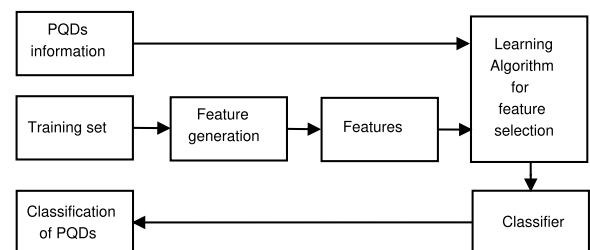

FIGURE 4. General framework of optimal feature selection for classification.

This method is used as an optimization technique for search problems and provides a good solution for power system application. It is also used as a population-based optimization approach and proved as a powerful tool for classifying the PQDs in the dynamic environment of the power system [140]. The multiple combinations of this technique help to select the best features for classification of power quality disturbances. This includes GA with WT [141], extended GA with WT [142] and GA with ST [143].

b: PARTICLE SWARM-BASED OPTIMIZATION TECHNIQUES

Particle swarm optimization technique is referred to as a population-based stochastic optimization technique [144]. This technique is also used for online and offline monitoring [145], [146] to extract the best subset of features using extreme learning machine (ELM) [147] and obtaining transient events using ICA [148]. Various combinations of this technique help to select the best features for classification of the PQ disturbances. This includes, Micro-genetic algorithms [149], statistical approach [150], and online sequential learning algorithm in [151]. The optimal feature selection using DT in the presence of RE sources (SPV and WE) is presented in [152].

c: ANT AND BEE COLONY BASED OPTIMIZATION TECHNIQUES

Day by day, the complexity of the system has been increasing with RE penetration. Therefore more efficient optimization techniques are required; researchers have started switching to optimal optimization techniques like Ant, Bee, and Hybrid optimization. These techniques have been used as a population-based search method in [153], [154], which mimics the food foraging behaviour of honey bee colonies as the best optimization techniques. A set of software agents provides the best solutions to a given optimization problem based on comparative data for various optimization problems called artificial ant colony optimization. Artificial bee colony optimization (ABCO) effectively addresses multiple PQ problems [155]. Thus, it has been widely used for better feature selection in power systems applications [156]. The profound information about ACO and BCO for optimization for feature selection has been presented in [157], [158]. Various combinations of this technique help for selecting the best features for classification of power quality disturbances. This includes, swarm intelligence technique [159], honey bee swarms [160], bacteria foraging technique [161], honey bee mating optimization SVM (HBMO SVM) [162] and multi-objective optimization [163]. Among those techniques, ABCO proved to solve real-world problems, so far. The merits and demerits of various optimization techniques for selection of best features for accurate classification are listed in Table 4. The significant merit observed from Table 4 that these techniques are suitable to solve computational problems and provide multiple solutions by adapting various changes associated with application-based problems. However, these techniques require pre-knowledge or sample genetic data for

accurate optimization of PQ features. Also, the comparative performance analysis of various optimization techniques is listed in Table 5. A simple comparison is made between the optimization techniques in terms of various attributes used by the researchers in current research. These attributes of optimization techniques are beneficial for knowing the performance level in the optimization of features for accurate classifications of PQDs. However, GA, ACO and BCO are found to be population-based techniques and provide optimal solutions. Also, PSO has been found to be an intelligence-based technique and provide excellent ease of application.

2) CLASSIFIERS FOR CLASSIFICATION OF PQDs

Classifiers are used for classification of PQ disturbances. These classifiers use a set of distinct features or parameters to characterise each event, where these features must be relevant to the object to be classified. Supervised and unsupervised classification techniques are widely reported for classification of PQ disturbances. Supervised learning techniques depend on the pre-trained data set to learn how to classify objects. However, there is no need for training in unsupervised learning like K-means, optics, and hierarchical clustering, etc. Multifarious AI-based classification techniques have been applied to classify PQ disturbances. These techniques are explained in below subsections.

a: ARTIFICIAL NEURAL NETWORKS BASED PQDs CLASSIFICATION

Neural Network is one of the essential nonlinear statistical data modelling tools. It is a vital tool for the statistical-based categorization of power system disturbances. Categorization using neural networks is a good alternative when enough data is available. Currently, research is emphasized on the classification of PQ disturbances using ANN because it can solve problems with multiple solutions. Higher-order statistics [126] and Wavelet-based NN classifier in synthesis, as well as real-time data-based analysis for PQDs classification, has been presented in [164]. The co-variance analysis of voltage waveform signature [165], modular neural network (MNN) classifier with the noisy and non-noisy environment [166], multi-layer perceptron network [167], back-propagation based ANN [168], NN structure [169] and DT hardware framework [170] have been reported for better understanding of PQDs classification. Also, statistical and AI techniques, such as ANN, fuzzy logic system, GA, and SVM, have been used to classify the PQDs in the utility grid [12]. Various PQDs caused by SPV penetration in utility grid are discussed in [171] and classified using MPNN, SVM, and LSSVM classifier have been presented in [172].

b: SUPPORT VECTOR MACHINE-BASED PQDs CLASSIFICATION

In the literature, the performance of the support vector machine (SVM) based classifier scheme to classify PQ disturbances is found to be better than conventional classifiers. The classification accuracy of SVM depends on the training data,

TABLE 4. Merits and demerits of optimization techniques.

GA	PSO	ACO	BCO
Merits			
GA is population based metaheuristic method.	PSO is intelligence based method.	ACO is population based algorithm.	BCO is population based algorithm
Concept is based on genetic data, easy to understand and programmable. It practically does not demand the knowledge of mathematics.	Concept is based on particle swarms, easily programmable, faster in convergence and mostly provides better solution.	Concept is based on ant colony, convergence is uncertain but guaranteed, and high flexibility to represent its knowledge.	Concept is based on bee colony, convergence is uncertain and high flexible which allow adjustments and represents a specific knowledge of the problem by observing nature of data.
The calculation in GA is simple, thus it provides good solution.	The calculation in PSO is very simple, thus it provides fast solution.	ACO is complex but it provides better solution than other methods.	Ability to explore local solutions, as it takes less number of steps. Also provides fast solution.
It solves computational problems with multiple solutions.	It solves computation problem with multiple solution.	It can adapt changes easily and provide accurate solution.	It can adapt changes easily and provides accurate solution.
It is suitable for combinatorial problems.	It is suitable for mutation calculation.	It is suitable for distributed computation which avoids premature convergence of optimization problems.	It is suitable for solving multidimensional and multi-modal optimization problems.
Demerits			
Theoretical analysis is not difficult but certain optimization problems (variant problems) can not be solved by GA.	Theoretical analysis is difficult. It has problems of scattering and optimization.	Theoretical analysis is difficult and it has sequences of random decisions, which is not independent.	Theoretical analysis is difficult and slows sequential processing.
Requires basic knowledge of software languages.	Requires basic knowledge of software languages.	Required basic knowledge of software languages.	Requires basic knowledge of software languages.
Genetic data are required and there is no guaranty that GA will find a global optimum.	Pre knowledge of some factors are required and very poorly suited to combinatorial problems.	Pre knowledge of various factors are required like distance and direction etc.	Pre knowledge of various factors is required like distance and direction etc.

TABLE 5. Performance analysis of optimization techniques.

Attributes	Optimization Techniques			
	GA	PSO	ACO	BCO
Inspiration	Process of natural selection	Convivial foraging behavior (flocking behavior of birds and the schooling behavior of fish)	Behavior of real ant colonies.	Behavior of real bee colonies
Agents	Agent is an entity that has no facets	Multi agent	ACO considers ants as agents	BCO considers bees as agents
Adaptive	Adaptive in nature	Adaptive in nature	Adaptive in nature	Adaptive in nature
Computational time	Less as compared to PSO	More as compared to GA	More as compared to BCO	Less as compared to ACO
Steps of computation	Requires more steps compared to PSO	Generating particle position, velocity and position update	Requires more steps compared to BCO	It requires about three times less iteration compared to ACO
Scalability	With respect to number of agents less scalable compared to PSO	With respect to number of agents more scalable compared to GA	With respect to number of agents ACO is more scalable	With respect to work region, BCO is more scalable
Optimal solution	Optimal features are extracted easily and provide good solution	Optimal features extracted easily and provide better solution compared to GA	Optimal features are extracted easily and provide good solution	It is more suitable and provides more diverse solution compared to ACO
Robustness	Less robust compared to PSO	More robust compared to GA	More robust compared to BCO	Less Robust compared to ACO
Convergence	Convergence time is high compared to PSO	Convergence time is less compared to GA	Convergence time is high compared to BCO	Convergence time is less compared to ACO
Applicability with/ hardware real time implementation with RE sources	Good	Very good	Very Good	Very Good

kernel parameters, and feature selection. Many researchers preferred SVM because of its ability to solve pattern recognition of classification problems. The ability of SVM using linear, polynomial kernel functions is discussed in [173]. The other SVM based classification techniques include, direct acyclic graph SVM [174], support vector data description (SVDD) [175], SVM and optimization using the advance immune algorithm [176], least-square SVM based classifier to estimate the significant contingencies in a standard IEEE-39 bus system in [177]. An overview of the SVM technique and its applicability in real-world engineering problems has been presented in [178]. Multi-class SVM architecture has been developed for identifying PQDs in the presence of solar-PV [179].

c: FUZZY EXPERT SYSTEM BASED PQDs CLASSIFICATION

In the fuzzy classification technique, a sample can be a member of many different classes with different values or degrees. Generally, the membership values for a particular sample are restricted such that the sum of all the membership values for a specific sample is equal to 1. Knowledgebase requires expertise in the choice of correct membership function and addition of new rules, if necessary, to analyse PQ disturbances. Novel FCM clustering-based algorithm reduces classification time and higher accuracy [180]. The other FES based classification algorithms include fuzzy reasoning approach [181], basic fuzzy logic [182], TS fuzzy logic [183], modified fuzzy min-max clustering NN [184] and FES classifier for PQ time series data mining using ST [185]. A linguistic

pattern based on the fuzzy logic technique [186] is used for feature optimization to enhance classification efficiency for the fast recognition and classification of PQDs. Classification of the PQDs with wind energy penetration in the utility grid using fuzzy c-means clustering has been presented in [22]. Moreover, literature evident that hybrid FES (the combination of FES with other classifiers) provided excellent results when compared to the individual FES.

d: NEURO-FUZZY SYSTEM BASED PQDs CLASSIFICATION

A Neuro-fuzzy system (NFS) is a fuzzy system which determines the fuzzy sets and fuzzy rules by processing data samples and employing a learning algorithm inspired by neural network theory. Improved neuro-fuzzy likes ANFIS, fuzzy rule net and GARIC, designed as unique multi-layer feed-forward neural networks. In these NFS, activation functions and weights are different from standard NN based interface, and this network also provides information like numeric, linguistic, logical, etc. In [187] authors proposed 3-D principal component analysis (PCA) along with NFS based classifiers for automatic classification of the PQDs. Designing of an advanced supervisory power system stability controller (SPSSC) using NFS has been presented in [188]. ICA for classifying the single and multiple PQDs [189] and classification of neuro-fuzzy systems based on their learning algorithm, fuzzy method, and structure from 2000 to till date has been explained in [190]. Also, the impact of Wind Energy (WE) sources on PQDs classification in distributed generation supported networks using modified ADALINE and an adaptive neuro-fuzzy information system has been presented in [191].

TABLE 6. Performance analysis of AI based PQD classification techniques.

Attributes	Classification techniques					
	ANN	SVM	NFS	FES	BC	HC
Knowledge representation	A	E	C	C	E	C
Ease of application	A	A	B	C	C	A
Robustness	B	A	B	C	C	A
Mathematical iterations	C	C	D	E	E	C
Learning ability	B	B	D	E	E	C
Computational complexity	C	D	D	E	C	C
Uncertainty tolerance	C	B	B	C	C	B
Convergence Time	A	A	A	C	C	A
Generalization Performance	B	A	D	E	C	A
Maintainability	C	C	C	D	C	C
Adaptability	C	C	C	D	D	A
Explanation ability	C	E	D	C	E	A
Efficiency	A	A	B	C	C	A
Imprecision tolerance	C	B	B	C	C	B
Applicability with hardware /real time implementation with RE sources	B	B	B	B	B	A

*Excellent-A, Very Good-B, Good-C, Marginal Good-D, Bad-E

e: BAYESIAN CLASSIFIER BASED PQDs CLASSIFICATION

Bayesian networks are one of the most effective techniques to solve a degree of uncertainty. Bayesian classifier (BC) uses a general inference mechanism to collect and incorporate the new information and evidence gathered in the study through Bayes' theorem. The Bayes theorem defines the conditional

probability (of x given y) as expressed below,

$$p\left(\frac{x}{y}\right) = \frac{P(x)P(y/x)}{P(y)} \tag{20}$$

where, x and y are events, P(x) and P(y) are the probabilities of x and y, P(x/y) is the conditional probability of x given y and P(y/x) is the conditional probability of y given x. In this way, BC updates a set of event probabilities according to the observed facts and the BC structure. In [192] authors used wavelet to decompose disturbing signals and extracted features related to the energy content of the scaled signal concerning the error signal. The BC further utilises these energy features for classification. For this accurate classification, PNN provides required sufficient training data for convergence of BC [193]. The combination of BC and SVM for hardware explanation of PQ disturbances is discussed in [194]. Although the probability density function of single and multiple PQ events must be identified in advance in Naive-BC, it is beneficial for the identification of signal patterns applied to classify different PQ disturbances in [195]. Application of BC networks in renewable energy sources, such as solar thermal, geothermal, hydroelectric energies, SPV, WE and biomass is explained in [196].

f: MISCELLANEOUS PQDs CLASSIFICATION TECHNIQUES

Apart from the techniques discussed in the preceding section, additional classification algorithms have performed an essential role in PQ monitoring. These algorithms are reviewed under the miscellaneous category for their effectiveness in power quality assessment. These includes, hardware and software architecture of expert system [197], rule-based model [198], improved generalized adaptive resonance theory (IGART) [199], recurrence quantification analysis [200], stochastic ordering theory with coded quickest classification [201], variety of supervised NN with online learning capabilities [202], attribute weighted artificial immune evolutionary classifier (AWAIEC) [203], spectral kurtosis to separate hybrid PQ disturbances [204], DT initialized fuzzy C-means clustering system based on ST [205], variational mode decomposition (VMD) [206], real-time calculation of the spectral kurtosis [207], online PQDs detection and classification using DWT, MM and SVD [208], curvelet transform and deep learning [209], rule-based ST and ada-boost with decision stump as weak classifier [87], random forests based PQ assessment framework [82], deep learning-based method and stacked auto-encoder, as a deep learning framework [210], ICA with a sparse autoencoder (SAE) for gaining automatically training features [211] and a new class-specific weighted random vector functional link network (CSWRVFLN) [137]. The performance analysis of different AI techniques is listed in Table 6. The comparison of the multiple attributes of significantly implemented AI-based classification techniques used by the researchers in current research. These attributes of ANN, SVM, NFS, FES, BC and HC techniques are beneficial for knowing the performance level of accurate classification of PQ disturbances. However,

hybrid classifiers (HC) is found as the best suitable classifier for accurate classification of PQ disturbances. Moreover, the concrete performance of various hybrid machine learning-AI models for classifying PQDs has been discussed in [212] and performance comparisons are provided for the selection of classification algorithms for a specific application. Besides, various merits and demerits of AI-based PQD classification techniques are listed in Table 7. It has been found from Table 7 that hybrid classifiers have higher learning capability with a stable solution with mixed PQ features in real-time. However, hybrid classifiers suffer from the processing speed due to the compatibility issue between two classifiers.

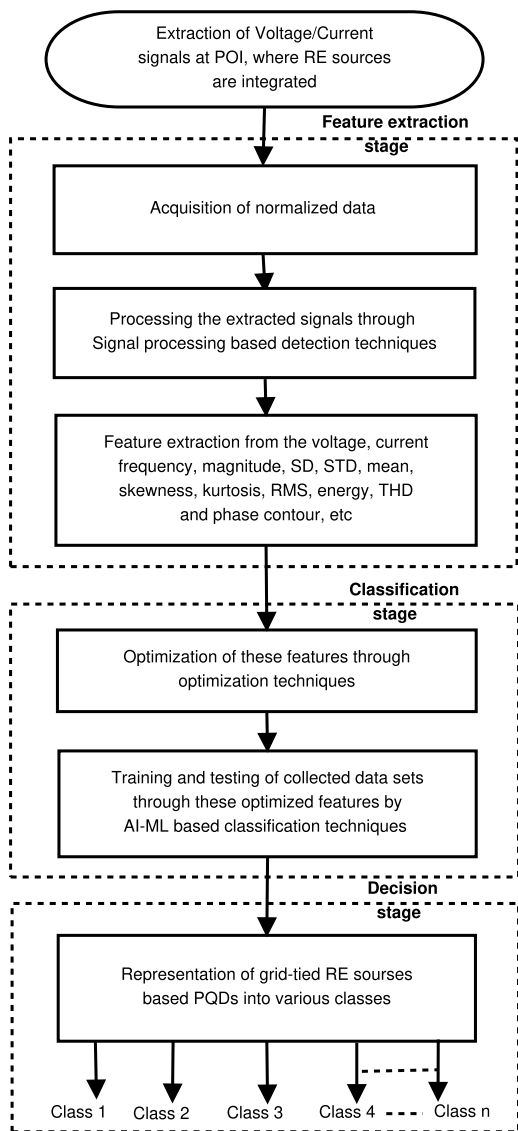

FIGURE 5. Generalized classification strategy with considering RE signals.

It has been observed from the literature survey that, RE sources are integrated at the point of interconnection and due to intermittent nature of output like continuous changes in solar irradiance, temperate and wind speed, generates various power quality disturbances. These disturbing signals are extracted at POI and fed into the signal processing based

detection techniques. During the feature extraction process, pre-processing like data normalization is done and features extracted. Redundant features are removed, and the best features are selected using optimization techniques. Obtained optimized features are fed into the classifiers for accurate classification, which is generally based on AI or ML-based classification techniques. In this stage, collected data are trained and tested through these classification algorithms. Finally, obtained PQDs signals are represented in the multiple classes. These classes depend on the type of algorithm, signals and application. The flowchart of the generalized classification strategy with considering RE signals is as illustrated in Fig. 5.

C. EFFECT OF NOISE ON DETECTION AND CLASSIFICATION TECHNIQUES

Power quality monitoring involves the detection and classification of PQDs. Detection and classification of PQDs in a utility grid with RE penetration itself is a challenging task, and it becomes even more complicated when noise is present in the signal. The detection and classification efficiency is primarily affected by the noise, which affects the extraction of essential features from the signal. Therefore, the detection and classification capability of the system is interrupted. Very few research works have been reported on the effect on the performance of detection and classification techniques due to noise present in the signal. Hence, there is a strong need for advancement in these techniques for monitoring of PQDs in the presence of noise.

Literature addressed research work on PQ disturbances such as sag, swell, transient, flicker, harmonics, and combinations of two or more. Different types of noisy conditions are considered in [3], [7], [50], [80], [170], [183] whereas [78], [132], [134], [205] consider PQ monitoring with and without noise. Also, DSP and FPGA processors with data acquisition equipment have been found capable of handling the computational burden in both noisy and non-noisy conditions of real-time operation [84], [169]. However, better identification of PQDs has been found with convolutional network structure in different noise levels [213]. Multi-fusion convolutional neural network for complex PQDs in the noisy environment has been presented in [214]. The comparative performance of detection and classification techniques in the noisy and non-noisy environment are illustrated in Table 8. Multiple PQDs are selected for the comparison of different detection and classification techniques based on the noise to conclude the efficiency. It has been found that without noise, maximum techniques have 100% accuracy. However, 20db noise has less efficiency compared to 30db noise, which shows lesser the signal to noise ratio, lesser the efficiency, hence performance of the techniques would be affected.

IV. EXPERIMENTAL SYSTEM BASED PQ ANALYSIS WITH RE PENETRATION

RE penetration plays an important role to meet the scarcity of power demand in the utility grid. The output of these

TABLE 7. Merits and demerits of AI based PQD classification techniques.

Classification techniques	Merits	Demerits
ANN	It provides flexibility for mathematical calculations. High accuracy in real-time applications.	Knowledge of neuron and requirements of sufficient layers. If NN is large, it requires high processing time.
SVM	It provides a stable solution with mixed features. High learning capability.	More time required for training and testing. Required large memory for multiple classifications.
Fuzzy logic based classifiers	It provides flexibility to analyze complex system. Accurate in modelling with mixed PQDs.	Fuzzy partition of the pattern space should be pre-specified. The number of fuzzy rules is not efficiently reduced by pruning the method in comparison with GA-based rule selection method.
Bayesian classifier	High classification accuracy with large data set. It provides flexible operation with large data set.	Large number of data required for accurate results. Less amount of the data affect the precision of the algorithm.
K-Nearest neighbor	Number of dimensions is the key component. High learning capability.	It takes more time to find the nearest neighbours in a large data set. Highly sensitive in noisy environment.
Hybrid classifier	High learning capability is the key component. It provides stable solution with mixed PQ features in real time.	Compatibility issue between two classifiers. It requires high processing time.

TABLE 8. Comparative analysis of PQD detection and classification techniques in presence of noise.

Power quality disturbance (%)	WT SVM [3]	GST TS-FL [183]	MG-ST [170]	ST-Dyn [80]	KF-FES [50]	ADALINE FNN [169]	SSD Hybrid dict. [132]	DRST DAG- SVM [134]	ST-NN [78]	ST DT FCM [205]						
	With Noise (db)						With and Without Noise (db)									
	N30	N20	N30	N20	N30	N20	WN	N20	WN	N30	WN	N20	WN	N20		
Normal	-	-	-	96	100	-	-	100	90	100	100	100	100	93	100	100
Swell	89	99	99.6	85	96	99	94	100	99	100	100	99	98.5	100	100	100
Sag	89	98	99.7	95	99	99	93	100	98	100	100	99.5	99	98	97	100
Interruption	-	100	99.5	85	96	98	92	100	100	100	98	97	92	-	-	100
Harmonics	97	89	100	97	99	94	90	98	90	100	100	100	99.5	100	95	97
Oscillatory transient	94	86	99.4	97	99	-	-	98	86	-	-	100	97.5	100	95	100
Flicker	99	98	99.7	91	96	-	-	94	87	100	100	99.5	97	100	97	100
Swell+Harmonics	98	95	100	97	98	96	92	97	88	86	82.7	99.5	97	100	98	-
Sag+Harmonics	97	94	100	95	97	97	93	98	89	84.6	83.4	100	99.5	100	95	-
Classification accuracy	95	95	98.5	93	98	97	92	98	92	96	96	99	98	100	96	100

*WN- Without noise, N20- SNR of 20db, N30-SNR of 30db.

TABLE 9. Performance analysis of PQD detection and classification techniques with RE penetration.

System	(SPV+WE) (60W+600KW)		(SPV+WE) (50kW+500kW)		(SPV+WE) (100kW+200KW)	(SPV+WE) (100,500kW +1MW)	(SPV+WE) (1MW+1.5MW)	(SPV+WE) (1,2MW+ 1.5,3MW)	(SPV+WE+FC) (60kW+600kW +60KW)
Detection algorithms	ST [172]		HST [152]		ST [120]	ST [22]	VMD [31]	ST [21]	ST [90]
Classification algorithms	M PNN	SVM	LS SVM	SVM	DT	SVM	Fuzzy C-means	DT	-
Detection (%)	-	-	-	-	-	95.8	-	-	<90
Classification (%)	98	98	98.33	97.2	97.4	95.97	<90	98.62	-

sources are unpredictable and intermittent, and this is one of the primary causes of PQ disturbances. Hence, the reliability and quality of power supply are largely affected. These PQ disturbances need to be detected first and then classified using signal processing and artificial intelligence-based techniques and then experimentally validated, to show the viability in a practical utility grid. A general experimental framework of the PQ monitoring system with RE penetration is depicted in Fig. 6. This experimental framework is realised from a 50Hz three-phase AC grid with RE sources (Wind and SPV) supplying power to nonlinear/sensitive loads. Meanwhile, PQ disturbances monitoring techniques are loaded on FPGA based hardware board. The current and voltage signals are sensed using hall-effect based sensors. Analog to digital converters are used to convert sensed voltage and current signals and then fed to algorithms. Digital storage oscilloscope is also used to display the captured waveforms. The experimental work reported in the literature on PQ monitoring has been presented in [90], [106], [120], [139], [152], [172], [191].

A general software-based framework of the PQ monitoring system is depicted in Fig. 7. This system is categorized into two different platforms, FPGA based software and computer-based software. FPGA based software platform includes input signal conversion, signal processing, interfacing with computers, memory organization and controlled output. Computer-based software platform sub-classified into real-time software and web tools. The real-time software platform provides disturbance alerts by checking the database. However, the web tools platform provides graphical tools for user processing [215]. The detection and classification accuracy of PQDs with RE penetration obtained from the experiment framework are illustrated in Table 9. The aim of selecting the different RES based configuration is to show the classification efficiency of various techniques. It has been found that classification efficiency also depends on the RES based configurations in a real-time scenario.

Comparative analysis of experimental work done since the last two decades with RE penetration is presented in Table 10.

TABLE 10. Comparative analysis of experimental work done since last two decade.

System	Detection techniques	Features used	Optimization techniques	Classification techniques	Noise	Result (%)	Year	References
Grid connected	WT	STD, mean skewness, kurtosis	SFS	SVM	Yes	99.43	2010	[56]
	DWT	Entropy norms	NN	FANN	No	99.66	2011	[216]
	WPE, MIST	STD	DT	DT	No	97	2015	[67]
	GMOCUW, ST, DB4W, GMOC, MGW, NDNM	STD	GA	-	No	<95	2016	[73]
	ST	Amplitude, phase, frequency	-	SVM	No	<80	2016	[134]
	DWT, HST	STD, mean, energy skewness, kurtosis, RMS	PSO	SVM, PNN, KNN	Yes	99.38	2014	[146]
	-	RMS	ANN	AI Kernel	Yes	89	2007	[164]
	-	HOS, covariance	-	ANN	Yes	70	2006	[165]
	MGST, GST, ST	STD	PSO	PSO, DT	Yes	98	2015	[170]
	WT	RMS, energy content	-	NN, LVQ, FSCL	No	93.76	2002	[217]
	WT	Energy content	-	FES	Yes	95.31	2004	[181]
	Not done	STD	SCICA	ICA	Yes	97	2015	[189]
	WT	FC, phase angle shift, THD	ANN	ANN, Fuzzy	Yes	98.19	2007	[218]
	FFT and envelope	Voltage, current	-	AWAIEC	-	-	2014	[203]
	Grid tied RE sources	FFT	HOS, spectral kurtosis	-	-	Yes	-	2016
FT with Internet-based PQ Monitoring System		Voltage, current, harmonics, RMS	-	-	No	-	2018	[215]
HT		Frequency	-	-	Yes	-	2018	[192]
RSHT		Voltage, frequency, energy	-	CSWRVFLN	Yes	-	2019	[137]
ST, HST, TTT, MM, WT		STD, energy content	-	SVM	Yes	100	2015	[120]
WT,ST		STD, Energy content	-	-	No	<90	2012	[90]
ST		STD, SMC, SPC, KMC, KPC	MPNN	SVMs, LSSVMs	No	98.33	2013	[172]
HST		STD, energy, skewness and kurtosis of phase contour	GA	SVM, DT	Yes	97.2	2014	[152]
ST		THD, frequency	-	-	Yes	<90	2018	[21]
VMD		Relative mode energy ratios, ZC, IA and frequencies	-	DT	Yes	98.62	2016	[31]
ST		Mean THD, SD	-	Fuzzy C-means	Yes	<90	2020	[20]
Morphological filters EMD-HT		Mean, SD, skewness kurtosis, entropy	-	SVM	Yes	<90	2020	[179]
Simulator	Orthogonal Empirical Mode Decomposition (OEMD)	Voltage, frequencies	-	-	Yes	<90	2018	[219]
	Grid simulator based system	-	-	-	Yes	<90	2013	[220]
	SCADA based system	-	-	-	-	2016	[221]	

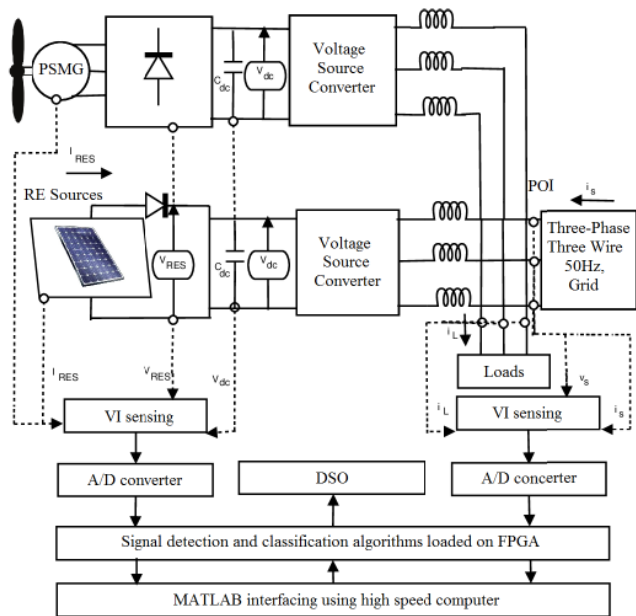

FIGURE 6. General hardware structure of PQ monitoring with RE penetration.

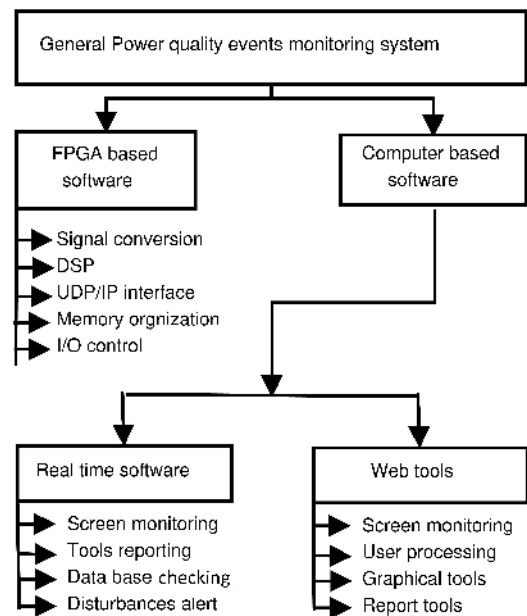

FIGURE 7. General software based framework of PQ monitoring system [215].

The tabled data explains the approach of many researchers for detection and classification of PQ disturbances. For this purpose, the table has been designed with grid-connected

mode and grid-tied RE sources mode with real-time simulator used in recent research. The tabled data is beneficial for beginners and researchers for selecting various features for

detection, optimization and classification even in the noisy condition. Also, in the aforementioned comparative analysis, synthesis results have been validated by experimental results, which illustrates the practical effectiveness of the system. It has been perceived from tabled data that research on PQ monitoring with RE penetration in hardware environments has been found very less and needs more attention to promote green energy for the smart grid. Hence, this comprehensive work aims to provide an experimental, online, or real-time based performance analysis, merits and demerits of various SP based AI techniques with RE penetration for benefiting the beginners and engineers in the field of PQ disturbances monitoring using research done in the last two decades.

TABLE 11. Performance evaluation of experiment based languages.

Programming language	Correct classification (%)	Time (sec)	Type of PQDs	Techniques	Ref.
VHDL	98.19	0.000016	Real	DWT+FL	[218]
	71.46	360	Real	ANN	[222]
	71.4	135	Real	DWT+FL	[218]
MATLAB	99.29	0.014	Real	RSHHT+CSWRVFLN	[137]
	<95	0.0255	Real	GMOCUW	[73]
	99.44	0.083	Real	FIR-DGT+T2FK-SVM	[106]
	99.08	0.9	Real	MST+DT	[84]
	<90	0.095	Real (WE)	ST+FCM	[20]
	94	-	Real (SPV)	Morphological filter+EMD-HT	[179]
	<90	-	Real (WE+SPV)	ST	[21]
	97.9	-	Real	HOS+ANN	[126]
	<95	≈0.028	Real (WE+SPV)	ST+SVM	[120]
	<96	≈0.024		HST+SVM	
	<97	≈0.028		TTT+SVM	
<98	≈0.022	MM+SVM			
		Deep convolutional network			
Python	98.52	0.5	Real (microgrid)	Deep convolutional network	[213]
C	69.14	5	Real	DWT+FL	[218]

TABLE 12. DAQs used in last three decades.

Years	DAQ systems
Before 1980s	Realized through analog circuit
1980 to 2000	Microprocessor and analog circuit
Current and 2000 on words	DSP based controller
Future	VLSI based SOPC controller

A. TECHNICAL DESCRIPTION OF THE EXPERIMENTAL FRAMEWORK WITH CONSIDERING PQ MONITORING TECHNIQUES

The selection of equipment and programming language with proper ratings is a difficult task for online simulation as well as the experimental framework. The overall cost, complexity, and compatibility with RE penetration also have some limitations. In [218] total 5000 iterations have been taken to check the accuracy and speed of the C, MATLAB and VHDL language. VHDL was found to be the fastest language for execution within 0.000016 seconds with 98.19 % classification efficiency compared to MATLAB (71.4%) and C (69.14%) language. Also, VHDL is an independent hardware

language and provides easy design implementation in a real-time scenario. However, in the case of simulation studies SP based techniques programmed in MATLAB language have better classification accuracy with less computational time compared to other software languages. All these algorithms are also applicable for WE, SPV and hybrid energy source based systems. The performance evaluation of real-time and software-based languages with their processing time is, as shown in Table 11. Also, data acquisition (DAQ) technologies are used for the recording of voltage and current signals for hardware implementation. Three decades with trends in DAQ systems are as presented in Table 12. The intention of Table 12 is to provide an easy way for selecting appropriate DAQ systems as per the present and future trends of DAQ. It has been noted down that the selection of the DAQ system may vary based on the different research application of PQ monitoring. However, a detailed analysis of technical descriptions of hardware used for PQ disturbance monitoring algorithms is carried out based on a thorough study of research articles cited in this article and provided in Table 13. Tabled data explains the details of hardware/real-time system, which include technical parameters, features used in various PQ monitoring techniques even in noisy conditions for benefiting the beginners and engineers for selecting specific PQ detection and classification technique and other equipment based on the hardware data used in previous researches.

V. KEY FINDINGS AND FUTURE RESEARCH WORK

Key findings of presented comprehensive review and future research work are described in the following subsections.

A. KEY FINDINGS

The developed review reveals the following key findings:-

- This review provides a general overview of power quality monitoring and its standards in the area of RE penetration into the utility grid, which is useful for grid operators for continuous monitoring of voltage, current and frequency levels.
- This review guides beginners in selecting various stages involved for PQ analysis and monitoring methodology.
- Multifarious signal processing (SP) based signal extraction techniques have been discussed for detection of PQ disturbances. The WT, ST, FT, HHT and MM are commonly used SP based techniques for detection of PQDs. It has been established that the adaptive signal processing based techniques can be a potential choice due to its superiority of fast and accurate detection in the real-time scenario.
- This review helps for the selection of a suitable mother wavelet function for detection of power quality disturbances with the wavelet-based signal extraction features. Daubechies db4 has been found most suitable wavelet for PQDs detection.
- Various artificial intelligence (AI) based classification techniques have been provided for categorizing PQD

TABLE 13. Technical description of hardware frame work of PQ monitoring systems reported in last two decades.

Techniques	Features	Description	Noise	Ref.
Chirp/z-transform	STD, mean, frequency	Source: Power amplifier, Programming language: MATLAB, Frequency estimation: Stanford research DS345 synthesized function generator, Signal acquisition: A 12 bit 4-channel serial-output A/D converter ADS7841, Embedded system: Xilinx- xc3s1000, Sampling frequency: 512 Hz, operation speed: of 33.74 MHz, Other specifications: embedded on the Spartan-3 Starter Board from Diligent.	Yes	[29]
FFT	RMS, voltage SD frequency and magnitudes	Source: Pacific power source power amplifier AMX3120, Programming language: Labview software, Power analyzer: Norma D6000, Sampling frequency: 3 MHz, Sampling rate: 6 MS/s, DSP controller: (DSK) TMS320C6711 Other specification: Anti-aliasing filters, RTDX as communication protocol with THS1206 12 bit A/D converter (THS1206) and C6711 32 bit floating-point DSP.	No	[42]
WT/SVM	RMS, GDR index	Source: Pacific Power Source power amplifier 320-AMX, Programming language: MATLAB, Sampling rate: 12.8-kHz, Signal acquisition: NI USB-6259 DAQ, Sampling frequency: 1.25 MS/s, V-I sensors: Hall-effect LV25-P and LA25-NP, Other specification: analog inputs has been converted with 16 bits of resolution.	Yes	[3]
Interpolated DFT/ high compression	Frequency, amplitude, phase angle	Source: Not given, Programming language: MATLAB, Signal acquisition: NI 6123, Power analyzer: Fluke 6100A, Other specification: A Pentium-4 with processor speed 2.66-GHz and Microsoft XP Service Pack 2 operating system.	Yes	[58]
ST and dynamics based hybrid method/ DT	Voltage, frequency, min- max	Source: Not given, Programming language: MATLAB, Embedded system: Xilinx Spartan XC2S200PQ208-FPGA has been utilized to control input/ output devices as well as communication system, DSP controller: Development of kernel algorithm with the help of TMS320C6713, Sampling frequency: 225 MHz, Sampling rate: 51.2 kHz (1024 samples/ cycle), Other specification: Signal conditioning circuit has been used to get power signals and 16 bit multi-channel A/D converter used for DAQ.	Yes	[80]
ST	RMS, THD	Source: 11 V 50Hz, Programming language: LabVIEW, Sampling rate: 200 kS/s, Other specification: System is consists of 16 bit ADC and SCKI-1600 module with universal serial bus has been utilized to enhanced the performance of the system. This module received the input analogue signals and sends data to computer.	No	[138]
Fast ST/ fuzzy-DT	Min-Max amplitude, STD	Source: Not given, Programming language: MATLAB, DSP controller: 32 bit floating point TI-TMS 320C6713, Other specification: Real-time data exchange as a communication protocol TI C6000 DSP.	Yes	[83]
EMD, FPGA	STD, envelop, Min-Max	Source: Not given, Programming language: MATLAB, DSP controller: SMIMS-versico CA8. It has been integrated with the combination of Samsung S5PC100 cortex A8 processor and a Xilinx XC6SLX150 FPGA chip, Sampling frequency:12.5 MHz.	No	[100]
DB4, mother WT, ST	STD, energy	Source: Motor-Alternator Set: DC Motor: 8 kW, 220 V, 45 A, 1500 rpm, Alternator: 9kVA, 440V, 13.9A, 1500 rpm, Programming language: MATLAB, DSO: 2 channel TDS 2002, Other specification: P-4, processor speed of 2.2 GHz with 1 GB RAM.	Yes	[105]
Digital filtering and MM	Amplitude, RMS	Source: 230V, 50Hz, Programming language: MATLAB, DAQ: NI 16-bit USB 9215 with PC for recording the signals, Sampling rate: 50 kS/s, Sampling frequency: 150 kHz, Other specification: Hall effect based LV 25-P and LA 25-NP sensors.	No	[118]
DWT, KF [121], RMS, FT, DWT, EKF [122]	Voltage magnitude	Source: 12 kV/ 380V with 3-phase utility transformer, Programming language: LabVIEW, DSP controller: PXI 8186 with the controller speed 2.2 GHz, Sampling rate: 200-kHz, Sampling frequency: 6.4kHz, Other specification: 16 analog input channels.	No	[121], [122]
Linear time frequency utility	RMS, THD, voltage, current	Source: voltage 0-300V, 50Hz, Programming language: MATLAB, DAQ: NI USB 6009, Other specification: NI modules full fill the expectations and offers 12 digital input/output channels, 32 bit counter and 8 analog input and output channels.	Yes	[130]
Double-resolution ST/Acyclic graph SVMs	Power signals	Source: Not given, Programming language: MATLAB, DSP controller: Management processing unit ARM Cortex M4 processor MK60DN- 512VLQ10 with DSP processor TMS320VC6745, Sampling rate: 250 ks/s, Sampling frequency: 36MHz, Other specification: Pre-process circuit, ADC converter of 16-b 6-channel serial output ADS 8556 and an anti-aliasing filter have been considered for DAQ system.	Yes	[134]
Bayes/SVM, GA	Skewness, variance extrema	Source: 400V, 50Hz, Programming language: MATLAB, Other specification: ADC unit based DAQ with signal sampling rate 20 kHz for all 4 channels and programmable digital filters are considered for the real time operation of the system.	No	[194]
FFT	HOS, spectral kurtosis	Source: Not given, Programming language: MATLAB, Embedded system: Artix-7 FPGA from Xilinx-XC7A100T, DAQ: DAC121S101 from National Semiconductor Sampling frequency: 10.24kHz, Other specification: Input range of the DAC has been varied between 0 to 4095.	Yes	[207]
WT	Voltage, frequency	Source: 115 kV, 60 Hz, Programming language: EMTDC/ PSCAD, Sampling frequency: 8333 Hz, digital time-domain simulation has been considered for the evolution of the algorithm and compared results with [43]. Decision has been made using the maximum likelihood criterion.	No	[41]
WT	Voltage, frequency	Source: 120V and 480 V, 60 Hz, Programming language: EMTDC/ PSCAD, Sampling frequency: 5882Hz, Gating schemes: UHP40, Control algorithm language: DSP via a Hot-Link. Other specification: Decision is made using the Maximum Likelihood criterion.	No	[43]
Euclidean squared distance/ BC	HOS, RMS	Source: Not given, Programming language: LabVIEW, Power analyzer: AFG3022B, FPGA Controller: NI-cRIO 9076 Embedded system: NI compact RIO 9076, Sampling frequency: 15.36 kHz, Other specification: 20 classes are classified.	Yes	[57]
WT/SVM	STD, RMS, energy skewness, kurtosis	Source: Not given, Programming language: MATLAB, Sampling rate: 3200 Hz, Other specification: Total 4096 points contain the disturbances and sampled at 256 points per cycle. However, 14 noiseless and 15 noisy signals have been taken as classifier input signal.	Yes	[56]
GMOCUW, MGW, NDNM, ST, GA	Frequency voltage deviation	Source: 300/30V, Programming language: PSCAD/EMTDC, Power analyzer: Chroma 61511, Sample frequency: 12800 Hz, Other specification: Oscilloscope used to display and record real-time voltage signals: a DELL PC with 4.00 GB of RAM, 2.3-GHz Intel Core i3 processor and has been used.	Yes	[73]
DWT/SV-data description (SVDD)	Detailed coefficients has been considered	Source: Not given, Programming language: ATP environment, Power analyzer: Yokogawa SL-1000 oscillographer, Sampling frequency: 10 MHz, Other specification: Remote communication system has been used.	No	[175]
ST	THD, power, frequency	Source: Not given, Programming language: MATLAB, Other specification: Proposed model has loaded on ML 605 target of OPAL-RT (RTDS) operated in hardware synchronization mode.	No	[21]
FT with Internet-based PQ Monitoring System	Voltage, current, harmonics, RMS	Source: Not given, Programming language: Microsoft ASP.NET, Microsoft Visual C#, LabVIEW, VHDL hardware description language, FPGA Controller: Virtex5 LX110T model FPGA, Sampling frequency: 6.4 MHz, Other specification: LV25-P voltage sensors, 9660 HIOKI current sensors of 1KA.	No	[215]
RSHHT/CSWRVFLN	Voltage, frequency, energy	Source: 3-phase,415V,50Hz, Programming language: MATLAB, FPGA Controller: Xilinx xc5vsx0t-3ff1136 FPGA, Sampling rat: 3.2KHz, Other specification: AD202JY voltage transducer.	Yes	[137]

signals in two or more different types according to their features. The GA, PSO, ANN, SVM, FEA, NFS and BC have been found to be commonly used classification techniques. It has been established that the issue of the number of decomposition levels required to keep away the possible loss of some well-connected information for classification of stationary and non-stationary signals with RE penetration requires best optimization techniques for fast and accurate classification. Thus, hybrid combination based classification techniques have been reported in this review.

- Noise present in the signal is one of the significant critical issues in the accurate feature detection and classification of PQDs. It is established that SP and AI-based techniques can be a potential choice due to their superiority in a noisy environment.
- Specific PQDs and their associated features during grid operating conditions in the presence of RES are reported for selecting suitable SP and AI-based techniques.
- This review presents an experimental architecture for RE penetration into the utility grid for power quality monitoring. Also, the technical description of the hardware framework has been provided for selecting

the hardware language with suitable data acquisition system.

B. FUTURE RESEARCH WORK

A broad scope for future research in the PQ monitoring with RE penetration may include:

- The detection and classification of multiple PQDs with various penetration levels of RES in a grid-tied mode in the presence of noise need to be investigated for PQ monitoring in smart grids.
- Variation of the strength of AC grid with RE penetration is the major source of PQ disturbances and monitoring of these disturbances using the machine, and deep learning-based techniques can be a possible future research problem.
- Study to select a generalized methodology for detection and classification of single and multiple PQDs with hybrid RE sources can also be a thrust area for researchers.
- The modern improvement in artificial intelligence-based algorithms and Deep-learning based algorithms have added to the extension of computer vision and image recognition ideas. Hence, it could be a significant focused area for power quality disturbances recognition.

VI. CONCLUSION

A comprehensive the state-of-the-art for different detection and classification techniques for the diagnosis of PQDs in the utility grid with RE penetration is presented in this article. The international research status with the details linked to the working principle of various PQ monitoring techniques (both in simulation and experimental studies) is presented in detail. Performance, merits and demerits of these techniques are summarised. The beginners in this area of research would be able to select the method based on the system requirements. Technical description of the hardware used for experimental work is also provided because of benefiting the designers and researchers in the field of PQ monitoring in the utility grid with RE penetration. Learning outcomes of this review and the possible scope of future work have been highlighted. Authors hope that this review will pave the way for new ideas on signal detection, optimization and classification techniques in association with the RE sources for the promotion of green and clean energy.

REFERENCES

- [1] O. Ellabban, H. Abu-Rub, and F. Blaabjerg, "Renewable energy resources: Current status, future prospects and their enabling technology," *Renew. Sustain. Energy Rev.*, vol. 39, pp. 748–764, Nov. 2014.
- [2] Y. Han, Y. Feng, P. Yang, L. Xu, Y. Xu, and F. Blaabjerg, "Cause, classification of voltage sag, and voltage sag emulators and applications: A comprehensive overview," *IEEE Access*, vol. 8, pp. 1922–1934, 2020.
- [3] M. D. Borrás, J. C. Bravo, and J. C. Montaño, "Disturbance ratio for optimal multi-event classification in power distribution networks," *IEEE Trans. Ind. Electron.*, vol. 63, no. 5, pp. 3117–3124, May 2016.
- [4] S. D. Ahmed, F. S. M. Al-Ismail, M. Shafiqullah, F. A. Al-Sulaiman, and I. M. El-Amin, "Grid integration challenges of wind energy: A review," *IEEE Access*, vol. 8, pp. 10857–10878, 2020.
- [5] H. Shareef, A. Mohamed, and A. A. Ibrahim, "An image processing based method for power quality event identification," *Int. J. Electr. Power Energy Syst.*, vol. 46, pp. 184–197, Mar. 2013.
- [6] H. Jiang, Y. Zheng, Z. Wang, L. Chen, and J. Peng, "An image processing based method for transient power quality classification," *Power Syst. Protection Control*, vol. 43, no. 13, pp. 72–78, 2015.
- [7] L. Lin, D. Wang, S. Zhao, L. Chen, and N. Huang, "Power quality disturbance feature selection and pattern recognition based on image enhancement techniques," *IEEE Access*, vol. 7, pp. 67889–67904, 2019.
- [8] D. Granados-Lieberman, R. J. Romero-Troncoso, R. A. Osornio-Rios, A. Garcia-Perez, and E. Cabal-Yepez, "Techniques and methodologies for power quality analysis and disturbances classification in power systems: A review," *IET Generat. Transmiss. Distrib.*, vol. 5, no. 4, pp. 519–529, Apr. 2011.
- [9] M. K. Saini and R. Kapoor, "Classification of power quality events—A review," *Int. J. Electr. Power Energy Syst.*, vol. 43, no. 1, pp. 11–19, Dec. 2012.
- [10] O. P. Mahela, A. G. Shaik, and N. Gupta, "A critical review of detection and classification of power quality events," *Renew. Sustain. Energy Rev.*, vol. 41, pp. 495–505, Jan. 2015.
- [11] S. Avdakovic, A. Nuhanovic, M. Kusljugic, and M. Music, "Wavelet transform applications in power system dynamics," *Electr. Power Syst. Res.*, vol. 83, no. 1, pp. 237–245, Feb. 2012.
- [12] S. Khokhar, A. A. B. M. Zin, A. S. B. Mokhtar, and M. Pesaran, "A comprehensive overview on signal processing and artificial intelligence techniques applications in classification of power quality disturbances," *Renew. Sustain. Energy Rev.*, vol. 51, pp. 1650–1663, Nov. 2015.
- [13] A. Augustine, R. D. Prakash, R. Xavier, and M. C. Parassery, "Review of signal processing techniques for detection of power quality events," *Amer. J. Eng. Appl. Sci.*, vol. 9, no. 2, pp. 364–370, Feb. 2016.
- [14] S. Vyas, R. Kumar, and R. Kavasseri, "Data analytics and computational methods for anti-islanding of renewable energy based distributed generators in power grids," *Renew. Sustain. Energy Rev.*, vol. 69, pp. 493–502, Mar. 2017.
- [15] O. A. Alimi, K. Ouahada, and A. M. Abu-Mahfouz, "A review of machine learning approaches to power system security and stability," *IEEE Access*, vol. 8, pp. 113512–113531, 2020.
- [16] X. Liang, "Emerging power quality challenges due to integration of renewable energy sources," *IEEE Trans. Ind. Appl.*, vol. 53, no. 2, pp. 855–866, Mar. 2017.
- [17] G. S. Chawda and A. G. Shaik, "Performance evaluation of adaline controlled DSTATCOM for multifarious load in weak AC grid," in *Proc. IEEE PES GTD Grand Int. Conf. Expo. Asia (GTD Asia)*, Mar. 2019, pp. 356–361.
- [18] G. S. Chawda, O. P. Mahela, N. Gupta, M. Khosravy, and T. Senjyu, "Incremental conductance based particle swarm optimization algorithm for global maximum power tracking of solar-PV under nonuniform operating conditions," *Appl. Sci.*, vol. 10, no. 13, p. 4575, Jul. 2020.
- [19] A. Q. Al-Shetwi, M. A. Hannan, K. P. Jern, M. Mansur, and T. M. I. Mahlia, "Grid-connected renewable energy sources: Review of the recent integration requirements and control methods," *J. Cleaner Prod.*, vol. 253, Apr. 2020, Art. no. 119831.
- [20] O. P. Mahela, B. Khan, H. H. Alhelou, and P. Siano, "Power quality assessment and event detection in distribution network with wind energy penetration using stockwell transform and fuzzy clustering," *IEEE Trans. Ind. Informat.*, vol. 16, no. 11, pp. 6922–6932, Nov. 2020.
- [21] A. G. Shaik and O. P. Mahela, "Power quality assessment and event detection in hybrid power system," *Electr. Power Syst. Res.*, vol. 161, pp. 26–44, Aug. 2018.
- [22] O. P. Mahela and A. G. Shaik, "Power quality recognition in distribution system with solar energy penetration using S-transform and fuzzy C-means clustering," *Renew. Energy*, vol. 106, pp. 37–51, Jun. 2017.
- [23] O. P. Mahela, B. Khan, H. H. Alhelou, and S. Tanwar, "Assessment of power quality in the utility grid integrated with wind energy generation," *IET Power Electron.*, early access, Jan. 2020. [Online]. Available: <https://digital-library.theiet.org/content/journals/10.1049/iet-pel.2019.1351>, doi: 10.1049/iet-pel.2019.1351.
- [24] G. S. Chawda and A. G. Shaik, "Smooth grid synchronization in weak AC grid with high wind energy penetration using distribution static compensator," in *Proc. 2nd Int. Conf. Smart Grid Renew. Energy (SGRE)*, Nov. 2019, pp. 1–6.
- [25] C. Li and R. Reimmuller, "Open phase detection in DER operation by using power quality data analytics," *IEEE Trans. Power Del.*, early access, Feb. 3, 2020, doi: 10.1109/TPWRD.2020.2971151.
- [26] D. Pal and B. K. Panigrahi, "Analysis and mitigation of the impact of ancillary services on anti-islanding protection of distributed generators," *IEEE Trans. Sustain. Energy*, early access, Mar. 23, 2020.
- [27] A. A. Abdelsalam, A. A. Salem, E. S. Oda, and A. A. Eldesouky, "Islanding detection of microgrid incorporating inverter based DGS using long short-term memory network," *IEEE Access*, vol. 8, pp. 106471–106486, 2020.
- [28] H. J. Green and T. Wind, "The IEEE grid interconnection standard: How will it affect wind power?" Nat. Renew. Energy Lab., Golden, CO, USA, Tech. Rep. NREL/CP-500-28409, 2000. [Online]. Available: <https://www.osti.gov/biblio/763399>
- [29] T. Lin and A. Domijan, "On power quality indices and real time measurement," *IEEE Trans. Power Del.*, vol. 20, no. 4, pp. 2552–2562, Oct. 2005.
- [30] S. De and S. Debnath, "Real-time cross-correlation-based technique for detection and classification of power quality disturbances," *IET Generat. Transmiss. Distrib.*, vol. 12, no. 3, pp. 688–695, Feb. 2018.
- [31] P. D. Achlerkar, S. R. Samantaray, and M. Sabarimalai Manikandan, "Variational mode decomposition and decision tree based detection and classification of power quality disturbances in grid-connected distributed generation system," *IEEE Trans. Smart Grid*, vol. 9, no. 4, pp. 3122–3132, Jul. 2018.
- [32] *Voltage Characteristics of Electricity Supplied by Public Electricity Networks*, EN Standard 50160, 2010.
- [33] C.-Y. Lee and Y.-X. Shen, "Optimal feature selection for power-quality disturbances classification," *IEEE Trans. Power Del.*, vol. 26, no. 4, pp. 2342–2351, Oct. 2011.
- [34] *IEEE Recommended Practice for Monitoring Electric Power Quality, Industrial and Commercial Applications*, IEEE Standards Association 1159-1995, 2009.
- [35] B. Singh, A. Chandra, and K. Al-Haddad, *Power Quality: Problems and Mitigation Techniques*. Hoboken, NJ, USA: Wiley, 2014.
- [36] M. M. Islam, E. Hossain, S. Padmanaban, and C. W. Brice, "A new perspective of wind power grid codes under unbalanced and distorted grid conditions," *IEEE Access*, vol. 8, pp. 15931–15944, 2020.

- [37] G. S. Chawda, A. G. Shaik, O. P. Mahela, S. Padmanaban, and J. B. Holm-Nielsen, "Comprehensive review of distributed facts control algorithms for power quality enhancement in utility grid with renewable energy penetration," *IEEE Access*, vol. 8, pp. 107614–107634, 2020.
- [38] O. P. Mahela and A. G. Shaik, "Power quality improvement in distribution network using DSTATCOM with battery energy storage system," *Int. J. Electr. Power Energy Syst.*, vol. 83, pp. 229–240, Dec. 2016.
- [39] G. S. Chawda and A. G. Shaik, "Adaptive reactive power control of DSTATCOM in weak AC grid with high wind energy penetration," in *Proc. IEEE 16th India Council Int. Conf. (INDICON)*, Dec. 2019, pp. 1–4.
- [40] R. N. Bracewell and R. N. Bracewell, *The Fourier Transform and its Applications*. New York, NY, USA: McGraw-Hill, 1986, pp. 31999.
- [41] M. Karimi, H. Mokhtari, and M. R. Iravani, "Wavelet based on-line disturbance detection for power quality applications," *IEEE Trans. Power Del.*, vol. 15, no. 4, pp. 1212–1220, 2000.
- [42] D. Gallo, C. Landi, and N. Rignano, "Real-time digital multifunction instrument for power quality integrated indexes measurement," *IEEE Trans. Instrum. Meas.*, vol. 57, no. 12, pp. 2769–2776, Dec. 2008.
- [43] H. Mokhtari, M. Karimi-Ghartemani, and M. R. Iravani, "Experimental performance evaluation of a wavelet-based on-line voltage detection method for power quality applications," *IEEE Trans. Power Del.*, vol. 17, no. 1, pp. 161–172, 2002.
- [44] T. X. Zhu, "Detection and characterization of oscillatory transients using matching pursuits with a damped sinusoidal dictionary," *IEEE Trans. Power Del.*, vol. 22, no. 2, pp. 1093–1099, Apr. 2007.
- [45] W. Huihui and W. Ping, "Comparison of detection methods for power quality in micro-grid," in *Proc. 6th Int. Conf. Power Electron. Syst. Appl. (PESA)*, 2015, pp. 1–8.
- [46] A. F. Bastos and S. Santoso, "Universal waveshape-based disturbance detection in power quality data using similarity metrics," *IEEE Trans. Power Del.*, vol. 35, no. 4, pp. 1779–1787, Aug. 2020.
- [47] M. Garrido, "The feedforward short-time Fourier transform," *IEEE Trans. Circuits Syst. II, Exp. Briefs*, vol. 63, no. 9, pp. 868–872, Sep. 2016.
- [48] U. Singh and S. N. Singh, "Application of fractional Fourier transform for classification of power quality disturbances," *IET Sci., Meas. Technol.*, vol. 11, no. 1, pp. 67–76, Jan. 2017.
- [49] G. Welch and G. Bishop. *The Kalman Filter*. [Online]. Available: https://www.cs.unc.edu/~welch/media/pdf/kalman_intro.pdf
- [50] A. A. Abdelsalam, A. A. Eldesouky, and A. A. Sallam, "Characterization of power quality disturbances using hybrid technique of linear Kalman filter and fuzzy-expert system," *Electr. Power Syst. Res.*, vol. 83, no. 1, pp. 41–50, Feb. 2012.
- [51] J. B. V. Reddy, P. K. Dash, R. Samantaray, and A. K. Moharana, "Fast tracking of power quality disturbance signals using an optimized unscented filter," *IEEE Trans. Instrum. Meas.*, vol. 58, no. 12, pp. 3943–3952, Dec. 2009.
- [52] M. Jazaeri and M. T. Nasrabadi, "A new fast and efficient artificial neural network based state estimator incorporated into a linear optimal regulator for power system control enhancement," *Electr. Power Compon. Syst.*, vol. 43, no. 6, pp. 644–655, Apr. 2015.
- [53] S. K. Singh, N. Sinha, A. K. Goswami, and N. Sinha, "Several variants of Kalman filter algorithm for power system harmonic estimation," *Int. J. Electr. Power Energy Syst.*, vol. 78, pp. 793–800, Jun. 2016.
- [54] A. Bagheri, M. Mardaneh, A. Rajaei, and A. Rahideh, "Detection of grid voltage fundamental and harmonic components using Kalman filter and generalized averaging method," *IEEE Trans. Power Electron.*, vol. 31, no. 2, pp. 1064–1073, Feb. 2016.
- [55] F. Allella, E. Chiodo, G. M. Giannuzzi, D. Lauria, and F. Mottola, "On-line estimation assessment of power systems inertia with high penetration of renewable generation," *IEEE Access*, vol. 8, pp. 62689–62697, 2020.
- [56] H. Eri ti, A. Uçar, and Y. Demir, "Wavelet-based feature extraction and selection for classification of power system disturbances using support vector machines," *Electr. Power Syst. Res.*, vol. 80, no. 7, pp. 743–752, Jul. 2010.
- [57] E. G. Ribeiro, T. M. Mendes, G. L. Dias, E. R. S. Faria, F. M. Viana, B. H. G. Barbosa, and D. D. Ferreira, "Real-time system for automatic detection and classification of single and multiple power quality disturbances," *Measurement*, vol. 128, pp. 276–283, Nov. 2018.
- [58] M. Zhang, K. Li, and Y. Hu, "A high efficient compression method for power quality applications," *IEEE Trans. Instrum. Meas.*, vol. 60, no. 6, pp. 1976–1985, Jun. 2011.
- [59] T. Zafar and W. G. Morsi, "Power quality and the un-decimated wavelet transform: An analytic approach for time-varying disturbances," *Electr. Power Syst. Res.*, vol. 96, pp. 201–210, Mar. 2013.
- [60] S. A. Deokar and L. M. Waghmare, "Integrated DWT–FFT approach for detection and classification of power quality disturbances," *Int. J. Electr. Power Energy Syst.*, vol. 61, pp. 594–605, Oct. 2014.
- [61] S. Chakraborty, A. Chatterjee, and S. K. Goswami, "A sparse representation based approach for recognition of power system transients," *Eng. Appl. Artif. Intell.*, vol. 30, pp. 137–144, Apr. 2014.
- [62] Z. Liu, Q. Hu, Y. Cui, and Q. Zhang, "A new detection approach of transient disturbances combining wavelet packet and tsallis entropy," *Neurocomputing*, vol. 142, pp. 393–407, Oct. 2014.
- [63] K. Thirumala, A. C. Umarikar, and T. Jain, "Estimation of single-phase and three-phase power-quality indices using empirical wavelet transform," *IEEE Trans. Power Del.*, vol. 30, no. 1, pp. 445–454, Feb. 2015.
- [64] Z. Liu, Y. Cui, and W. Li, "A classification method for complex power quality disturbances using EEMD and rank wavelet SVM," *IEEE Trans. Smart Grid*, vol. 6, no. 4, pp. 1678–1685, Jul. 2015.
- [65] S. M. A. Bhuiyan, J. Khan, and G. Murphy, "WPD for detecting disturbances in presence of noise in smart grid for PQ monitoring," *IEEE Trans. Ind. Appl.*, vol. 54, no. 1, pp. 702–711, Jan. 2018.
- [66] D. De Yong, S. Bhowmik, and F. Magnago, "An effective power quality classifier using wavelet transform and support vector machines," *Expert Syst. Appl.*, vol. 42, nos. 15–16, pp. 6075–6081, Sep. 2015.
- [67] Z. Liu, Y. Cui, and W. Li, "Combined power quality disturbances recognition using wavelet packet entropies and S-transform," *Entropy*, vol. 17, no. 12, pp. 5811–5828, Aug. 2015.
- [68] M. B. Latran and A. Teke, "A novel wavelet transform based voltage sag/swell detection algorithm," *Int. J. Electr. Power Energy Syst.*, vol. 71, pp. 131–139, Oct. 2015.
- [69] H. M. Banayem, A. Doroudi, and M. P. Azimi, "Flicker source tracing by wavelet transform," *Electr. Power Compon. Syst.*, vol. 43, no. 4, pp. 412–421, Feb. 2015.
- [70] S. Upadhyaya, S. Mohanty, and C. N. Bhende, "Hybrid methods for fast detection and characterization of power quality disturbances," *J. Control, Autom. Electr. Syst.*, vol. 26, no. 5, pp. 556–566, Oct. 2015.
- [71] L. C. M. Andrade, M. Oleskovicz, and R. A. S. Fernandes, "Adaptive threshold based on wavelet transform applied to the segmentation of single and combined power quality disturbances," *Appl. Soft Comput.*, vol. 38, pp. 967–977, Jan. 2016.
- [72] S. Upadhyaya and S. Mohanty, "Localization and classification of power quality disturbances using maximal overlap discrete wavelet transform and data mining based classifiers," *IFAC-PapersOnLine*, vol. 49, no. 1, pp. 437–442, 2016.
- [73] Y. Zhang, T. Y. Ji, M. S. Li, and Q. H. Wu, "Identification of power disturbances using generalized morphological open-closing and close-opening undecimated wavelet," *IEEE Trans. Ind. Electron.*, vol. 63, no. 4, pp. 2330–2339, Apr. 2016.
- [74] R. Kumar, B. Singh, D. T. Shahani, and C. Jain, "Dual-tree complex wavelet transform-based control algorithm for power quality improvement in a distribution system," *IEEE Trans. Ind. Electron.*, vol. 64, no. 1, pp. 764–772, Jan. 2017.
- [75] P. Sinha, S. K. Goswami, and S. Nath, "Wavelet-based technique for identification of harmonic source in distribution system," *Int. Trans. Electr. Energy Syst.*, vol. 26, no. 12, pp. 2552–2572, Dec. 2016.
- [76] O. P. Mahela and A. G. Shaik, "Power quality detection in distribution system with wind energy penetration using discrete wavelet transform," in *Proc. 2nd Int. Conf. Adv. Comput. Commun. Eng.*, May 2015, pp. 328–333.
- [77] R. G. Stockwell, L. Mansinha, and R. P. Lowe, "Localization of the complex spectrum: The S transform," *IEEE Trans. Signal Process.*, vol. 44, no. 4, pp. 998–1001, Apr. 1996.
- [78] M. Uyar, S. Yildirim, and M. T. Gencoglu, "An expert system based on S-transform and neural network for automatic classification of power quality disturbances," *Expert Syst. Appl.*, vol. 36, no. 3, pp. 5962–5975, Apr. 2009.
- [79] M. J. B. Reddy, R. K. Raghupathy, K. P. Venkatesh, and D. K. Mohanta, "Power quality analysis using discrete orthogonal S-transform (DOST)," *Digit. Signal Process.*, vol. 23, no. 2, pp. 616–626, Mar. 2013.
- [80] S. He, K. Li, and M. Zhang, "A real-time power quality disturbances classification using hybrid method based on S-transform and dynamics," *IEEE Trans. Instrum. Meas.*, vol. 62, no. 9, pp. 2465–2475, Sep. 2013.
- [81] G. Q. Liu and L. N. Wu, "Rapid power quality detection based on generalized HS-transform," in *Applied Mechanics and Materials*, vol. 568. New York, NY, USA: Trans Tech Publications, 2014, pp. 223–226.
- [82] M. V. Reddy and R. Sodhi, "A modified S-transform and random forests-based power quality assessment framework," *IEEE Trans. Instrum. Meas.*, vol. 67, no. 1, pp. 78–89, Jan. 2018.

- [83] M. Biswal and P. K. Dash, "Measurement and classification of simultaneous power signal patterns with an S-transform variant and fuzzy decision tree," *IEEE Trans. Ind. Informat.*, vol. 9, no. 4, pp. 1819–1827, Nov. 2013.
- [84] T. Zhong, S. Zhang, G. Cai, Y. Li, B. Yang, and Y. Chen, "Power quality disturbance recognition based on multiresolution S-transform and decision tree," *IEEE Access*, vol. 7, pp. 88380–88392, 2019.
- [85] P. R. Babu, P. K. Dash, S. K. Swain, and S. Sivanagaraju, "A new fast discrete S-transform and decision tree for the classification and monitoring of power quality disturbance waveforms," *Int. Trans. Electr. Energy Syst.*, vol. 24, no. 9, pp. 1279–1300, Sep. 2014.
- [86] H. Eri ti, O. Yildirim, B. Eri ti, and Y. Demir, "Automatic recognition system of underlying causes of power quality disturbances based on S-transform and extreme learning machine," *Int. J. Electr. Power Energy Syst.*, vol. 61, pp. 553–562, Oct. 2014.
- [87] M. V. Reddy and R. Sodhi, "A rule-based S-transform and AdaBoost based approach for power quality assessment," *Electr. Power Syst. Res.*, vol. 134, pp. 66–79, May 2016.
- [88] J. Yi, M. Zhou, Z. Li, and J. Li, "A novel technique for fundamental and harmonic parameter estimation using nonergodic S-transform," *IEEE Trans. Instrum. Meas.*, vol. 68, no. 10, pp. 3503–3513, Oct. 2019.
- [89] M. Fooladi and A. Akbari Foroud, "Recognition and assessment of different factors which affect flicker in wind turbines," *IET Renew. Power Gener.*, vol. 10, no. 2, pp. 250–259, Feb. 2016.
- [90] P. K. Ray, N. Kishor, and S. R. Mohanty, "Islanding and power quality disturbance detection in grid-connected hybrid power system using wavelet and S-transform," *IEEE Trans. Smart Grid*, vol. 3, no. 3, pp. 1082–1094, Sep. 2012.
- [91] N. Senroy, S. Suryanarayanan, and P. F. Ribeiro, "An improved Hilbert–Huang method for analysis of time-varying waveforms in power quality," *IEEE Trans. Power Syst.*, vol. 22, no. 4, pp. 1843–1850, Nov. 2007.
- [92] M. Manjula, S. Mishra, and A. V. R. S. Sarma, "Empirical mode decomposition with Hilbert transform for classification of voltage sag causes using probabilistic neural network," *Int. J. Electr. Power Energy Syst.*, vol. 44, no. 1, pp. 597–603, Jan. 2013.
- [93] D. Granados-Lieberman, M. Valtierra-Rodriguez, L. Morales-Hernandez, R. Romero-Troncoso, and R. Osornio-Rios, "A Hilbert transform-based smart sensor for detection, classification, and quantification of power quality disturbances," *Sensors*, vol. 13, no. 5, pp. 5507–5527, Apr. 2013.
- [94] M. J. Afroni, D. Sutanto, and D. Stirling, "Analysis of nonstationary power-quality waveforms using iterative Hilbert Huang transform and SAX algorithm," *IEEE Trans. Power Del.*, vol. 28, no. 4, pp. 2134–2144, Oct. 2013.
- [95] O. Ozgonenel, T. Yalcin, I. Guney, and U. Kurt, "A new classification for power quality events in distribution systems," *Electr. Power Syst. Res.*, vol. 95, pp. 192–199, Feb. 2013.
- [96] S. Shukla, S. Mishra, and B. Singh, "Power quality event classification under noisy conditions using EMD-based de-noising techniques," *IEEE Trans. Ind. Informat.*, vol. 10, no. 2, pp. 1044–1054, May 2014.
- [97] D. Saxena, S. N. Singh, K. S. Verma, and S. K. Singh, "HHT-based classification of composite power quality events," *Int. J. Energy Sector Manage.*, vol. 8, no. 2, pp. 146–159, May 2014.
- [98] R. Kumar, B. Singh, and D. T. Shahani, "Recognition of single-stage and multiple power quality events using Hilbert–Huang transform and probabilistic neural network," *Electr. Power Compon. Syst.*, vol. 43, no. 6, pp. 607–619, Apr. 2015.
- [99] M. Sahani and P. K. Dash, "Automatic power quality events recognition based on Hilbert Huang transform and weighted bidirectional extreme learning machine," *IEEE Trans. Ind. Informat.*, vol. 14, no. 9, pp. 3849–3858, Sep. 2018.
- [100] P.-Y. Chen, Y.-C. Lai, and J.-Y. Zheng, "Hardware design and implementation for empirical mode decomposition," *IEEE Trans. Ind. Electron.*, vol. 63, no. 6, pp. 3686–3694, Jun. 2016.
- [101] M. Mishra, M. Sahani, and P. K. Rout, "An islanding detection algorithm for distributed generation based on Hilbert–Huang transform and extreme learning machine," *Sustain. Energy, Grids Netw.*, vol. 9, pp. 13–26, Mar. 2017.
- [102] H. Chen, Y. Sun, and Y. Cheng, "Harmonic and inter-harmonic detection of grid-connected distributed generation based on modified mathematical morphology filter and Hilbert–Huang transformation," in *Proc. IEEE 6th Int. Power Electron. Motion Control Conf. (IPEMC)*, May 2009, pp. 1155–1160.
- [103] S. J. Huang, C. L. Huang, and C. T. Hsieh, "Application of Gabor transform technique to supervise power system transient harmonics," *IEE Proc. Gener. Transmiss. Distrib.*, vol. 143, no. 5, pp. 461–466, Sep. 1996.
- [104] W. Qian, Y. Fei, Z. Yi, and C. En, "Gabor wigner transform based on fractional Fourier transform for low signal to noise ratio signal detection," in *Proc. OCEANS*, Shanghai, China, 2016, pp. 1–4.
- [105] Z. Moravej, M. Pazoki, M. Niasati, and A. A. Abdoos, "A hybrid intelligence approach for power quality disturbances detection and classification," *Int. Trans. Electr. Energy Syst.*, vol. 23, no. 7, pp. 914–929, Oct. 2013.
- [106] S. Naderian and A. Salemnia, "Method for classification of PQ events based on discrete Gabor transform with FIR window and T2FK-based SVM and its experimental verification," *IET Gener. Transmiss. Distrib.*, vol. 11, no. 1, pp. 133–141, Jan. 2017.
- [107] J. Zhao, Z. He, and Q. Qian, "Detection of power quality disturbances based on generalized morphological filter and information theory," in *Proc. Asia-Pacific Power Energy Eng. Conf. (APPEEC)*, Mar. 2009, pp. 1–4.
- [108] S. Ouyang and J. Wang, "A new morphology method for enhancing power quality monitoring system," *Int. J. Electr. Power Energy Syst.*, vol. 29, no. 2, pp. 121–128, Feb. 2007.
- [109] S. Gautam and S. Brahma, "Properties of mathematical morphology based filter for online filtering of power system signals," in *Proc. 41st North Amer. Power Symp. (NAPS)*, Oct. 2009, pp. 1–5.
- [110] S. Gautam and S. M. Brahma, "Guidelines for selection of an optimal structuring element for mathematical morphology based tools to detect power system disturbances," in *Proc. IEEE Power Energy Soc. Gen. Meeting*, Jul. 2012, pp. 1–6.
- [111] R. Huang, S. Ouyang, and Y. Shi, "A precise location method of power quality disturbances based on morphological edge detection," in *Proc. Asia-Pacific Power Energy Eng. Conf. (APPEEC)*, Mar. 2012, pp. 1–5.
- [112] Y. Zhang, T. Ji, M. Li, and Q. Wu, "Detection and classification of low-frequency power disturbances using a morphological max-lifting scheme," in *Proc. IEEE PES Asia-Pacific Power Energy Eng. Conf. (APPEEC)*, Dec. 2013, pp. 1–5.
- [113] J. Zhu, T. Ji, M. Li, Q. Wu, and J. Smith, "Detection and classification of power disturbances using mathematical morphology with trapezoid structuring elements and signal envelopes," in *Proc. Innov. Smart Grid Technol. Conf. Eur. (ISGT-Eur.)*, Oct. 2014, pp. 1–6.
- [114] E. M. dos Santos, J. P. J. Neto, G. Marchesan, and G. Cardoso, "Power system frequency estimation using morphological prediction of clarke components," *Electr. Power Syst. Res.*, vol. 122, pp. 208–217, May 2015.
- [115] T. Chakravorti, R. Patnaik, and P. Dash, "A morphological filter based disturbance detection and classification technique for dfig wind farm based microgrid," in *Proc. IEEE Power, Commun. Inf. Technol. Conf. (PCITC)*, Oct. 2015, pp. 979–985.
- [116] Z. M. Chen, M. S. Li, T. Y. Ji, and Q. H. Wu, "Power quality disturbance identification using morphological pattern spectrum and probabilistic neural network," in *Proc. IEEE Power Energy Soc. Gen. Meeting*, Jul. 2015, pp. 1–5.
- [117] Y. Chen, T. Y. Ji, M. S. Li, and Q. H. Wu, "Power quality disturbance detection based on morphology singular entropy," in *Proc. IEEE Innov. Smart Grid Technol. Asia (ISGT ASIA)*, Nov. 2015, pp. 1–5.
- [118] T. Radil, P. M. Ramos, F. M. Janeiro, and A. Cruz Serra, "PQ monitoring system for real-time detection and classification of disturbances in a single-phase power system," *IEEE Trans. Instrum. Meas.*, vol. 57, no. 8, pp. 1725–1733, Aug. 2008.
- [119] M. V. Rodriguez, L. A. M. Hernandez, J. P. B. Rangel, and A. D. Gonzalez, "Real-time monitoring of voltage variations using mathematical morphology," *IEEE Latin Amer. Trans.*, vol. 14, no. 5, pp. 2138–2145, May 2016.
- [120] S. R. Mohanty, N. Kishor, P. K. Ray, and J. P. S. Catalao, "Comparative study of advanced signal processing techniques for islanding detection in a hybrid distributed generation system," *IEEE Trans. Sustain. Energy*, vol. 6, no. 1, pp. 122–131, Jan. 2015.
- [121] E. Pérez and J. Barros, "A proposal for on-line detection and classification of voltage events in power systems," *IEEE Trans. Power Del.*, vol. 23, no. 4, pp. 2132–2138, Oct. 2008.
- [122] E. Pérez and J. Barros, "Application of advanced digital signal processing tools for analysis of voltage events in power systems," *Int. J. Electr. Eng. Edu.*, vol. 46, no. 3, pp. 211–224, Jul. 2009.
- [123] C.-T. Hsieh, J.-M. Lin, and S.-J. Huang, "Slant transform applied to electric power quality detection with field programmable gate array design enhanced," *Int. J. Electr. Power Energy Syst.*, vol. 32, no. 5, pp. 428–432, Jun. 2010.

- [124] G.-S. Hu and F.-F. Zhu, "An improved chirplet transform and its application for harmonics detection," *Circuits Syst.*, vol. 2, no. 3, p. 107, 2011.
- [125] R. Kapoor and M. K. Saini, "Hybrid demodulation concept and harmonic analysis for single/multiple power quality events detection and classification," *Int. J. Electr. Power Energy Syst.*, vol. 33, no. 10, pp. 1608–1622, Dec. 2011.
- [126] G. D. J. Martinez-Figueroa, D. Morinigo-Sotelo, A. L. Zorita-Lamadrid, L. Morales-Velazquez, and R. D. J. Romero-Troncoso, "FPGA-based smart sensor for detection and classification of power quality disturbances using higher order statistics," *IEEE Access*, vol. 5, pp. 14259–14274, 2017.
- [127] J. J. G. de la Rosa, A. Agüera-Pérez, J. C. Palomares-Salas, J. M. Sierra-Fernández, and A. Moreno-Muñoz, "A novel virtual instrument for power quality surveillance based in higher-order statistics and case-based reasoning," *Measurement*, vol. 45, no. 7, pp. 1824–1835, Aug. 2012.
- [128] S. Jashfar, S. Esmaili, M. Zareian-Jahromi, and M. Rahmani, "Classification of power quality disturbances using S-transform and TT-transform based on the artificial neural network," *Turkish J. Electr. Eng. Comput. Sci.*, vol. 21, no. 6, pp. 1528–1538, 2013.
- [129] D. D. Ferreira, J. M. de Seixas, A. S. Cerqueira, and C. A. Duque, "Exploiting principal curves for power quality monitoring," *Electr. Power Syst. Res.*, vol. 100, pp. 1–6, Jul. 2013.
- [130] N. Abidullah, A. Abdullah, A. Z. Sha'ameri, N. Shamsudin, N. Ahmad, and M. Jopri, "Real-time power quality disturbances detection and classification system," *World Appl. Sci. J.*, vol. 32, no. 8, pp. 1637–1651, 2014.
- [131] O. P. Mahela and A. G. Shaik, "Detection of power quality events associated with grid integration of 100 kW solar PV plant," in *Proc. Int. Conf. Energy Econ. Environ. (ICEEE)*, Mar. 2015, pp. 1–6.
- [132] M. S. Manikandan, S. R. Samantaray, and I. Kamwa, "Detection and classification of power quality disturbances using sparse signal decomposition on hybrid dictionaries," *IEEE Trans. Instrum. Meas.*, vol. 64, no. 1, pp. 27–38, Jan. 2015.
- [133] T. Chakravorti and P. K. Dash, "Multiclass power quality events classification using variational mode decomposition with fast reduced kernel extreme learning machine-based feature selection," *IET Sci., Meas. Technol.*, vol. 12, no. 1, pp. 106–117, Jan. 2018.
- [134] J. Li, Z. Teng, Q. Tang, and J. Song, "Detection and classification of power quality disturbances using double resolution S-transform and DAG-SVMs," *IEEE Trans. Instrum. Meas.*, vol. 65, no. 10, pp. 2302–2312, Oct. 2016.
- [135] A. A. P. Biscaro, R. A. F. Pereira, M. Kezunovic, and J. R. S. Mantovani, "Integrated fault location and power-quality analysis in electric power distribution systems," *IEEE Trans. Power Del.*, vol. 31, no. 2, pp. 428–436, Apr. 2016.
- [136] R. Kumar, B. Singh, and D. T. Shahani, "Symmetrical components-based modified technique for power-quality disturbances detection and classification," *IEEE Trans. Ind. Appl.*, vol. 52, no. 4, pp. 3443–3450, Jul. 2016.
- [137] M. Sahani and P. K. Dash, "FPGA-based online power quality disturbances monitoring using reduced-sample HHT and class-specific weighted RVFLN," *IEEE Trans. Ind. Informat.*, vol. 15, no. 8, pp. 4614–4623, Aug. 2019.
- [138] M. J. B. Reddy, D. K. Mohanta, and K. Sagar, "A multifunctional real-time power quality monitoring system using stockwell transform," *IET Sci., Meas. Technol.*, vol. 8, no. 4, pp. 155–169, Jul. 2014.
- [139] D. A. Elvira-Ortiz, D. Morinigo-Sotelo, O. Duque-Perez, A. Y. Jaen-Cuellar, R. A. Osornio-Rios, and R. D. J. Romero-Troncoso, "Methodology for flicker estimation and its correlation to environmental factors in photovoltaic generation," *IEEE Access*, vol. 6, pp. 24035–24047, 2018.
- [140] M. A. Rodriguez-Guerrero, A. Y. Jaen-Cuellar, R. D. Carranza-Lopez-Padilla, R. A. Osornio-Rios, G. Herrera-Ruiz, and R. D. J. Romero-Troncoso, "Hybrid approach based on GA and PSO for parameter estimation of a full power quality disturbance parameterized model," *IEEE Trans. Ind. Informat.*, vol. 14, no. 3, pp. 1016–1028, Mar. 2018.
- [141] Y.-Y. Hong and Y. Chen, "Placement of power quality monitors using enhanced genetic algorithm and wavelet transform," *IET Gener., Transmiss. Distrib.*, vol. 5, no. 4, pp. 461–466, 2011.
- [142] M.-H. Wang and Y.-F. Tseng, "A novel analytic method of power quality using extension genetic algorithm and wavelet transform," *Expert Syst. Appl.*, vol. 38, no. 10, pp. 12491–12496, 2011.
- [143] P. Sánchez, F. G. Montoya, F. Manzano-Agugliaro, and C. Gil, "Genetic algorithm for S-transform optimisation in the analysis and classification of electrical signal perturbations," *Expert Syst. Appl.*, vol. 40, no. 17, pp. 6766–6777, Dec. 2013.
- [144] J. Kennedy, "Particle swarm optimization," in *Encyclopedia of Machine Learning*, C. Sammut and G. I. Webb, Eds. Boston, MA, USA: Springer, 2011, pp. 760–766. [Online]. Available: https://link.springer.com/referenceworkentry/10.1007/978-0-387-30164-8_630 howto cite, doi: 10.1007/978-0-387-30164-8_630.
- [145] M. Hajian and A. A. Foroud, "A new hybrid pattern recognition scheme for automatic discrimination of power quality disturbances," *Measurement*, vol. 51, pp. 265–280, May 2014.
- [146] M. Hajian, A. A. Foroud, and A. A. Abdoos, "New automated power quality recognition system for online/offline monitoring," *Neurocomputing*, vol. 128, pp. 389–406, Mar. 2014.
- [147] R. Ahila, V. Sadasivam, and K. Manimala, "An integrated PSO for parameter determination and feature selection of ELM and its application in classification of power system disturbances," *Appl. Soft Comput.*, vol. 32, pp. 23–37, Jul. 2015.
- [148] D. D. Ferreira, J. M. de Seixas, A. S. Cerqueira, C. A. Duque, M. H. J. Bollen, and P. F. Ribeiro, "Extracting the transient events from power system signals by independent component analysis," *Int. Trans. Electr. Energy Syst.*, vol. 26, no. 4, pp. 884–900, Apr. 2016.
- [149] A. Y. Jaen-Cuellar, L. Morales-Velazquez, R. D. J. Romero-Troncoso, D. Morinigo-Sotelo, and R. A. Osornio-Rios, "Micro-genetic algorithms for detecting and classifying electric power disturbances," *Neural Comput. Appl.*, vol. 28, no. S1, pp. 379–392, Dec. 2017.
- [150] C. He, Q. Shu, T. Liu, and X. Han, "A time-domain statistical approach for harmonics separation and analysis," *Int. Trans. Electr. Energy Syst.*, vol. 27, no. 1, p. e2239, Jan. 2017.
- [151] M. Wang, H. Zhou, S. Yang, L. Jin, and L. Jiao, "Robust compressive features based power quality events classification with Analog-Digital mixing network (ADMN)," *Neurocomputing*, vol. 171, pp. 685–692, Jan. 2016.
- [152] P. K. Ray, S. R. Mohanty, N. Kishor, and J. P. S. Catalao, "Optimal feature and decision tree-based classification of power quality disturbances in distributed generation systems," *IEEE Trans. Sustain. Energy*, vol. 5, no. 1, pp. 200–208, Jan. 2014.
- [153] B. Biswal, P. K. Dash, and S. Mishra, "A hybrid ant colony optimization technique for power signal pattern classification," *Expert Syst. Appl.*, vol. 38, no. 5, pp. 6368–6375, May 2011.
- [154] M. Dorigo and C. Blum, "Ant colony optimization theory: A survey," *Theor. Comput. Sci.*, vol. 344, nos. 2–3, pp. 243–278, Nov. 2005.
- [155] S. Biswas, A. Chatterjee, and S. K. Goswami, "An artificial bee colony-least square algorithm for solving harmonic estimation problems," *Appl. Soft Comput.*, vol. 13, no. 5, pp. 2343–2355, May 2013.
- [156] S.-J. Huang and X.-Z. Liu, "Application of artificial bee colony-based optimization for fault section estimation in power systems," *Int. J. Electr. Power Energy Syst.*, vol. 44, no. 1, pp. 210–218, Jan. 2013.
- [157] M. Dorigo and M. Birattari, "Ant colony optimization," in *Encyclopedia of Machine Learning*. Berlin, Germany: Springer, 2010, pp. 36–39. [Online]. Available: [https://scholar.google.com/scholar?hl=en&as_sdt=0%2C5&q=Ant+colony+optimization%2C%27%27+in+Encyclopedia+of+Machine+Learning+Springer&btnG=](https://scholar.google.com/scholar?hl=en&as_sdt=0%2C5&q=Ant+colony+optimization%2C%27%27+in+Encyclopedia+of+Machine+Learning+Springer&btnG=27+in+Encyclopedia+of+Machine+Learning+Springer&btnG=27+in+Encyclopedia+of+Machine+Learning+Springer&btnG=27+in+Encyclopedia+of+Machine+Learning+Springer&btnG=)
- [158] A. Chikhalikar and A. Darade, "Swarm intelligence techniques: Comparative study of ACO and BCO," *Self*, vol. 4, p. 5, 1995. [Online]. Available: <https://scholar.google.com/scholar?q=A.%20Chikhalikar%2C%20A.%20Darade%2C%20Swarm%20Intelligence%20Techniques%3A%20comparative%20study%20of%20ACO%20and%20BCO.%20Self%204%2C%205%20281995%29>
- [159] B. Chandra Mohan and R. Baskaran, "A survey: Ant colony optimization based recent research and implementation on several engineering domain," *Expert Syst. Appl.*, vol. 39, no. 4, pp. 4618–4627, Mar. 2012.
- [160] D. Karaboga, B. Gorkemli, C. Ozturk, and N. Karaboga, "A comprehensive survey: Artificial bee colony (ABC) algorithm and applications," *Artif. Intell. Rev.*, vol. 42, no. 1, pp. 21–57, Jun. 2014.
- [161] S. Jagadeesh and B. Biswal, "Time frequency analysis and classification of power quality events using bacteria foraging algorithm," in *Computational Intelligence in Data Mining (Smart Innovation, Systems and Technologies)*, vol. 33, L. Jain, H. Behera, J. Mandal, and D. Mohapatra, Eds. New Delhi, India: Springer, 2015, pp. 345–352. [Online]. Available: https://link.springer.com/chapter/10.1007/978-81-322-2202-6_31

- [162] J.-L. Wu, P.-C. Chang, C.-C. Tsao, and C.-Y. Fan, "A patent quality analysis and classification system using self-organizing maps with support vector machine," *Appl. Soft Comput.*, vol. 41, pp. 305–316, Apr. 2016.
- [163] M. F. Shaaban, A. H. Osman, and F. M. Aseeri, "A multi-objective allocation approach for power quality monitoring devices," *IEEE Access*, vol. 7, pp. 40866–40877, 2019.
- [164] I. Monedero, C. Leon, J. Roperio, A. Garcia, J. M. Elena, and J. C. Montano, "Classification of electrical disturbances in real time using neural networks," *IEEE Trans. Power Del.*, vol. 22, no. 3, pp. 1288–1296, Jul. 2007.
- [165] O. N. Gerek, D. G. Ece, and A. Barkana, "Covariance analysis of voltage waveform signature for power-quality event classification," *IEEE Trans. Power Del.*, vol. 21, no. 4, pp. 2022–2031, Oct. 2006.
- [166] C. N. Bhende, S. Mishra, and B. K. Panigrahi, "Detection and classification of power quality disturbances using S-transform and modular neural network," *Electr. Power Syst. Res.*, vol. 78, no. 1, pp. 122–128, Jan. 2008.
- [167] I. N. da Silva, D. H. Spatti, R. A. Flauzino, L. H. B. Liboni, and S. F. dos Reis Alves, "Recognition of disturbances related to electric power quality using MLP networks," in *Artificial Neural Networks*. Cham, Switzerland: Springer, 2017. [Online]. Available: https://link.springer.com/chapter/10.1007/978-3-319-43162-8_16, doi: 10.1007/978-3-319-43162-8_16.
- [168] C. B. Khadse, M. A. Chaudhari, and V. B. Borghate, "Conjugate gradient back-propagation based artificial neural network for real time power quality assessment," *Int. J. Electr. Power Energy Syst.*, vol. 82, pp. 197–206, Nov. 2016.
- [169] M. Valtierra-Rodriguez, R. de Jesus Romero-Troncoso, R. A. Osornio-Rios, and A. Garcia-Perez, "Detection and classification of single and combined power quality disturbances using neural networks," *IEEE Trans. Ind. Electron.*, vol. 61, no. 5, pp. 2473–2482, May 2014.
- [170] N. Huang, S. Zhang, G. Cai, and D. Xu, "Power quality disturbances recognition based on a multiresolution generalized S-transform and a PSO-improved decision tree," *Energies*, vol. 8, no. 1, pp. 549–572, Jan. 2015.
- [171] K. W. Kow, Y. W. Wong, R. K. Rajkumar, and R. K. Rajkumar, "A review on performance of artificial intelligence and conventional method in mitigating PV grid-tied related power quality events," *Renew. Sustain. Energy Rev.*, vol. 56, pp. 334–346, Apr. 2016.
- [172] P. K. Ray, S. R. Mohanty, and N. Kishor, "Classification of power quality disturbances due to environmental characteristics in distributed generation system," *IEEE Trans. Sustain. Energy*, vol. 4, no. 2, pp. 302–313, Apr. 2013.
- [173] C. Aneesh, S. Kumar, P. M. Hisham, and K. P. Soman, "Performance comparison of variational mode decomposition over empirical wavelet transform for the classification of power quality disturbances using support vector machine," *Procedia Comput. Sci.*, vol. 46, pp. 372–380, Jan. 2015.
- [174] B. K. Panigrahi, P. K. Dash, and J. B. V. Reddy, "Hybrid signal processing and machine intelligence techniques for detection, quantification and classification of power quality disturbances," *Eng. Appl. Artif. Intell.*, vol. 22, no. 3, pp. 442–454, Apr. 2009.
- [175] A. E. Lazzaretti, D. M. J. Tax, H. V. Neto, and V. H. Ferreira, "Novelty detection and multi-class classification in power distribution voltage waveforms," *Expert Syst. Appl.*, vol. 45, pp. 322–330, Mar. 2016.
- [176] B. Biswal, M. K. Biswal, P. K. Dash, and S. Mishra, "Power quality event characterization using support vector machine and optimization using advanced immune algorithm," *Neurocomputing*, vol. 103, pp. 75–86, Mar. 2013.
- [177] B. P. Soni, A. Saxena, and V. Gupta, "Supervised learning paradigm based on least square support vector machine for contingency ranking in a large power system," in *Proc. Int. Congr. Inf. Commun. Technol.* Singapore: Springer, 2016, pp. 531–539. [Online]. Available: https://link.springer.com/chapter/10.1007/978-981-10-0767-5_55, doi: 10.1007/978-981-10-0767-5_55.
- [178] S. Salcedo-Sanz, J. L. Rojo-Álvarez, M. Martínez-Ramón, and G. Camps-Valls, "Support vector machines in engineering: An overview," *Wiley Interdiscipl. Rev. Data Mining Knowl. Discovery*, vol. 4, no. 3, pp. 234–267, May 2014.
- [179] S. Prakash, S. Purwar, and S. R. Mohanty, "Adaptive detection of islanding and power quality disturbances in a grid-integrated photovoltaic system," *Arabian J. Sci. Eng.*, vol. 45, pp. 6297–6310, 2020. [Online]. Available: <https://doi.org/10.1007/s13369-020-04378-w>
- [180] G. Sahu, B. Biswal, and A. Choubey, "Non-stationary signal classification via modified fuzzy C-means algorithm and improved bacterial foraging algorithm," *Int. J. Numer. Model. Electron. Netw., Devices Fields*, vol. 30, no. 2, p. e2181, Mar. 2017.
- [181] T. X. Zhu, S. K. Tso, and K. L. Lo, "Wavelet-based fuzzy reasoning approach to power-quality disturbance recognition," *IEEE Trans. Power Del.*, vol. 19, no. 4, pp. 1928–1935, Oct. 2004.
- [182] G. S. Chawda and A. G. Shaik, "Fuzzy logic based control algorithm for DSTATCOM connected to weak AC grid," in *Proc. 2nd Int. Conf. Power, Energy Environ. Towards Smart Technol. (ICEPE)*, Jun. 2018, pp. 1–6.
- [183] L. Xiaosheng and L. Bo, "Recognition of power quality disturbances based on T-S fuzzy logic," in *Proc. 5th Int. Conf. Instrum. Meas., Commun. Control (IMCCC)*, Sep. 2015, pp. 302–305.
- [184] M. Seera, C. P. Lim, C. K. Loo, and H. Singh, "A modified fuzzy min-max neural network for data clustering and its application to power quality monitoring," *Appl. Soft Comput.*, vol. 28, pp. 19–29, Mar. 2015.
- [185] H. S. Behera, P. K. Dash, and B. Biswal, "Power quality time series data mining using S-transform and fuzzy expert system," *Appl. Soft Comput.*, vol. 10, no. 3, pp. 945–955, Jun. 2010.
- [186] X. Liu, B. Liu, and D. Xu, "Recognition and classification of power quality disturbances on the basis of pattern linguistic values," *J. Electr. Eng. Technol.*, vol. 11, no. 2, pp. 309–319, 2016.
- [187] V. F. Pires, T. G. Amaral, and J. F. Martins, "Power quality disturbances classification using the 3-D space representation and PCA based neuro-fuzzy approach," *Expert Syst. Appl.*, vol. 38, no. 9, pp. 11911–11917, 2011.
- [188] A. Sallama, M. Abbod, and G. Taylor, "Supervisory power system stability control using neuro-fuzzy system and particle swarm optimization algorithm," in *Proc. 49th Int. Universities Power Eng. Conf. (UPEC)*, Sep. 2014, pp. 1–6.
- [189] D. D. Ferreira, J. M. D. Seixas, and A. S. Cerqueira, "A method based on independent component analysis for single and multiple power quality disturbance classification," *Electr. Power Syst. Res.*, vol. 119, pp. 425–431, Feb. 2015.
- [190] K. V. Shihabudheen and G. N. Pillai, "Recent advances in neuro-fuzzy system: A survey," *Knowl.-Based Syst.*, vol. 152, pp. 136–162, Jul. 2018.
- [191] R. K. Patnaik and P. K. Dash, "Impact of wind farms on disturbance detection and classification in distributed generation using modified adaline network and an adaptive neuro-fuzzy information system," *Appl. Soft Comput.*, vol. 30, pp. 549–566, May 2015.
- [192] Y. Luo, K. Li, Y. Li, D. Cai, C. Zhao, and Q. Meng, "Three-layer Bayesian network for classification of complex power quality disturbances," *IEEE Trans. Ind. Informat.*, vol. 14, no. 9, pp. 3997–4006, Sep. 2018.
- [193] S. Mishra, C. N. Bhende, and B. K. Panigrahi, "Detection and classification of power quality disturbances using S-transform and probabilistic neural network," *IEEE Trans. Power Del.*, vol. 23, no. 1, pp. 280–287, Jan. 2008.
- [194] S. Gunal, O. N. Gerek, D. G. Ece, and R. Edizkan, "The search for optimal feature set in power quality event classification," *Expert Syst. Appl.*, vol. 36, no. 7, pp. 10266–10273, 2009.
- [195] M. R. Khan, S. K. Padhi, B. N. Sahu, and S. Behera, "Non stationary signal analysis and classification using FTT transform and naive bayes classifier," in *Proc. IEEE Power, Commun. Inf. Technol. Conf. (PCITC)*, Oct. 2015, pp. 967–972.
- [196] M. Borunda, O. A. Jaramillo, A. Reyes, and P. H. Ibarguengoytia, "Bayesian networks in renewable energy systems: A bibliographical survey," *Renew. Sustain. Energy Rev.*, vol. 62, pp. 32–45, Sep. 2016.
- [197] R. Lima, D. Quiroga, C. Reineri, and F. Magnago, "Hardware and software architecture for power quality analysis," *Comput. Electr. Eng.*, vol. 34, no. 6, pp. 520–530, Nov. 2008.
- [198] A. Rodríguez, J. A. Aguado, F. Martín, J. J. López, F. Muñoz, and J. E. Ruiz, "Rule-based classification of power quality disturbances using S-transform," *Electr. Power Syst. Res.*, vol. 86, pp. 113–121, May 2012.
- [199] K. S. Yap, C. P. Lim, and M. T. Au, "Improved GART neural network model for pattern classification and rule extraction with application to power systems," *IEEE Trans. Neural Netw.*, vol. 22, no. 12, pp. 2310–2323, Dec. 2011.
- [200] Z. Moravej, M. Pazoki, and A. A. Abdoos, "Wavelet transform and multi-class relevance vector machines based recognition and classification of power quality disturbances," *Eur. Trans. Electr. Power*, vol. 21, no. 1, pp. 212–222, Jan. 2011.
- [201] S.-C. Lin, C.-C. Liu, M.-Y. Hsieh, S.-T. Su, and W.-H. Chung, "Coded quickest classification with applications in bandwidth-efficient smart grid monitoring," *IEEE Trans. Inf. Forensics Security*, vol. 13, no. 12, pp. 3122–3136, Dec. 2018.

- [202] L. C. Jain, M. Seera, C. P. Lim, and P. Balasubramaniam, "A review of online learning in supervised neural networks," *Neural Comput. Appl.*, vol. 25, nos. 3–4, pp. 491–509, Sep. 2014.
- [203] H. Y. Li, Y. Fu, and D. Zhao, "Identification of power quality disturbances based on FFT and attribute weighted artificial immune evolutionary classifier," *Appl. Mech. Mater.*, vols. 530–531, pp. 277–280, Feb. 2014.
- [204] J. de la Rosa, J. Sierra-Fernández, J. Palomares-Salas, A. Agüera-Pérez, and Á. Montero, "An application of spectral kurtosis to separate hybrid power quality events," *Energies*, vol. 8, no. 9, pp. 9777–9793, Sep. 2015.
- [205] O. P. Mahela and A. G. Shaik, "Recognition of power quality disturbances using S-transform based ruled decision tree and fuzzy C-means clustering classifiers," *Appl. Soft Comput.*, vol. 59, pp. 243–257, Oct. 2017.
- [206] A. A. Abdoos, P. K. Mianaei, and M. R. Ghadikolaei, "Combined VMD-SVM based feature selection method for classification of power quality events," *Appl. Soft Comput.*, vol. 38, pp. 637–646, Jan. 2016.
- [207] Á. Quirós-Olozábal, J.-J. González-de-la-Rosa, M.-Á. Cifredo-Chacón, and J.-M. Sierra-Fernández, "A novel FPGA-based system for real-time calculation of the spectral kurtosis: A prospective application to harmonic detection," *Measurement*, vol. 86, pp. 101–113, May 2016.
- [208] M. Lopez-Ramirez, E. Cabal-Yepe, L. Ledesma-Carrillo, H. Miranda-Vidales, C. Rodríguez-Donate, and R. Lizarraga-Morales, "FPGA-based online PQD detection and classification through DWT, mathematical morphology and SVD," *Energies*, vol. 11, no. 4, p. 769, Mar. 2018.
- [209] H. Liu, F. Hussain, Y. Shen, S. Arif, A. Nazir, and M. Abubakar, "Complex power quality disturbances classification via curvelet transform and deep learning," *Electr. Power Syst. Res.*, vol. 163, pp. 1–9, Oct. 2018.
- [210] J. Ma, J. Zhang, L. Xiao, K. Chen, and J. Wu, "Classification of power quality disturbances via deep learning," *IETE Tech. Rev.*, vol. 34, no. 4, pp. 408–415, Jul. 2017.
- [211] X. Shi, H. Yang, Z. Xu, X. Zhang, and M. R. Farahani, "An independent component analysis classification for complex power quality disturbances with sparse auto encoder features," *IEEE Access*, vol. 7, pp. 20961–20966, 2019.
- [212] J. C. Bravo-Rodríguez, F. J. Torres, and M. D. Borrás, "Hybrid machine learning models for classifying power quality disturbances: A comparative study," *Energies*, vol. 13, no. 11, p. 2761, Jun. 2020.
- [213] R. Gong and T. Ruan, "A new convolutional network structure for power quality disturbance identification and classification in micro-grids," *IEEE Access*, vol. 8, pp. 88801–88814, 2020.
- [214] W. Qiu, Q. Tang, J. Liu, and W. Yao, "An automatic identification framework for complex power quality disturbances based on multifusion convolutional neural network," *IEEE Trans. Ind. Informat.*, vol. 16, no. 5, pp. 3233–3241, May 2020.
- [215] O. Yildirim, B. Eristi, H. Eristi, S. Unal, Y. Erol, and Y. Demir, "FPGA-based online power quality monitoring system for electrical distribution network," *Measurement*, vol. 121, pp. 109–121, Jun. 2018.
- [216] J. G. M. S. Decanini, M. S. Tonelli-Neto, F. C. V. Malange, and C. R. Minussi, "Detection and classification of voltage disturbances using a fuzzy-ARTMAP-wavelet network," *Electr. Power Syst. Res.*, vol. 81, no. 12, pp. 2057–2065, Dec. 2011.
- [217] J. Huang, M. Negnevitsky, and D. T. Nguyen, "A neural-fuzzy classifier for recognition of power quality disturbances," *IEEE Trans. Power Del.*, vol. 17, no. 2, pp. 609–616, Apr. 2002.
- [218] M. B. I. Reaz, F. Choong, M. S. Sulaiman, F. Mohd-Yasin, and M. Kamada, "Expert system for power quality disturbance classifier," *IEEE Trans. Power Del.*, vol. 22, no. 3, pp. 1979–1988, Jul. 2007.
- [219] H. R. Singh, S. R. Mohanty, N. Kishor, and K. A. Thakur, "Real-time implementation of signal processing techniques for disturbances detection," *IEEE Trans. Ind. Electron.*, vol. 66, no. 5, pp. 3550–3560, May 2019.
- [220] J. Eloy-García, J. M. Guerrero, and J. C. Vasquez, "Grid simulator for power quality assessment of micro-grids," *IET Power Electron.*, vol. 6, no. 4, pp. 700–709, Apr. 2013.
- [221] C. Gouveia, D. Rua, F. Ribeiro, L. Miranda, J. M. Rodrigues, C. L. Moreira, and J. A. P. Lopes, "Experimental validation of smart distribution grids: Development of a microgrid and electric mobility laboratory," *Int. J. Electr. Power Energy Syst.*, vol. 78, pp. 765–775, Jun. 2016.
- [222] M. R. Ahsan, M. I. Ibrahimy, O. O. Khalifa, and M. H. Ullah, "VHDL modeling of EMG signal classification using artificial neural network," *J. Appl. Sci.*, vol. 12, no. 3, pp. 244–253, Mar. 2012.



GAJENDRA SINGH CHAWDA (Graduate Student Member, IEEE) was born in Mandsaur, India, in 1986. He received the Diploma degree in electrical engineering from the Government Polytechnic College, Jaora, India, in 2004, the B.E. degree in electrical and electronics engineering from Rajiv Gandhi Proudhyogiki Vishwavidyalaya, Bhopal, India, in 2008, and the M.Tech. degree in electrical power system from NIT Kurukshetra, Haryana, India, in 2013. He is currently pursuing the Ph.D. degree with the Department of Electrical Engineering, IIT Jodhpur, Jodhpur, India. He has published various research articles in reputed Journals and International conferences. His research interests include power electronics, power quality, DFACTS devices, renewable energy penetration, weak ac grid, and smart grid control.



ABDUL GAFOOR SHAIK (Member, IEEE) received the Ph.D. degree in power systems. He is currently an Associate Professor with the Department of Electrical Engineering, IIT Jodhpur, Jodhpur. He has an industrial and academic research experience of more than 20 years. He has published over 50 research articles in reputed Journals, International conferences, and book chapters. He has wide research experience in the area of power system protection and power quality. His research interests include the development of power system protection algorithms using multi-resolution analysis, such as wavelet transform and S-transform and power quality mitigation in distribution network with RE sources using adaptive control algorithms. The courses taught by him include power system protection, electrical machines, power systems, power electronics, smart grid, and basic electrical engineering. He always excelled in academics and awarded a Gold Medal at Graduate and Post Graduate level. He was a recipient of the Best Paper Award from institution of engineers India, in 2015. His core team comprises of highly skilled students pursuing postgraduate and doctoral degrees in the area of power quality, induction motor protection, power system protection, and smart grid.



MAHMOOD SHAIK (Graduate Student Member, IEEE) received the B.Tech. degree in electrical and electronics engineering from Acharya Nagajuna University, Guntur, in 2007, and the M.Tech. degree in high voltage engineering from Jawaharlal Nehru Technological University, Kakinada, in 2012. He is currently pursuing the Ph.D. degree with IIT Jodhpur. He has published research article in various IEEE international conferences. He is interested in signal processing and

AI applications for distribution system protection and power quality in the presence of renewable energy sources.



SANJEEVIKUMAR PADMANABAN (Senior Member, IEEE) received the bachelor's degree in electrical engineering from the University of Madras, Chennai, India, in 2002, the master's degree (Hons.) in electrical engineering from Pondicherry University, Puducherry, India, in 2006, and the Ph.D. degree in electrical engineering from the University of Bologna, Bologna, Italy, in 2012.

He was an Associate Professor with VIT University, from 2012 to 2013. In 2013, he joined the National Institute of Technology, India, as a Faculty Member. In 2014, he was invited as a Visiting Researcher with the Department of Electrical Engineering, Qatar University, Doha, Qatar, funded by the Qatar National Research Foundation (Government of Qatar). He continued his research activities with the Dublin Institute of Technology, Dublin, Ireland, in 2014. He was an Associate Professor with the Department of Electrical and Electronics Engineering, University of Johannesburg, Johannesburg, South Africa, from 2016 to 2018. Since 2018, he has been a Faculty Member with the Department of Energy Technology, Aalborg University, Esbjerg, Denmark. He has authored more than 300 scientific articles. He was a recipient of the Best Paper cum Most Excellence Research Paper Award from IET-SEISCON 2013, IET-CEAT 2016, the IEEE-EECSI 2019, the IEEE-CENCON 2019, and five best paper awards from ETAERE 2016 sponsored Lecture Notes in Electrical Engineering, Springer book. He is a Fellow of the Institution of Engineers, India, the Institution of Electronics and Telecommunication Engineers, India, and the Institution of Engineering and Technology, U.K. He is an Editor/Associate Editor/Editorial Board for refereed journals, in particular the IEEE SYSTEMS JOURNAL, the IEEE TRANSACTIONS ON INDUSTRY APPLICATIONS, IEEE ACCESS, *IET Power Electronics*, and *International Transaction on Electrical Energy Systems* (Wiley), and the Subject Editor for the *IET Renewable Power Generation*, *IET Generation, Transmission and Distribution*, and *FACTS Journal* (Canada).



JENS BO HOLM-NIELSEN received the M.Sc. degree in agricultural systems, crops and soil science from KVL, Royal Veterinary and Agricultural University, Copenhagen, Denmark, in 1980, and the Ph.D. degree in process analytical technologies for biogas systems, Aalborg University, Esbjerg, Denmark, in 2008, where he is currently with the Department of Energy Technology. He is the Head of the Esbjerg Energy Section, Aalborg University. He is the Head of the Research Group, Center for

Bioenergy and Green Engineering established in 2009. He has vast experience in the field of biorefinery concepts and biogas production-anaerobic digestion. He has implemented projects of bioenergy systems in Denmark with provinces and European states. He was the Technical Advisor for many industries in this field. He has executed many large-scale European Union and United Nations projects in research aspects of bioenergy, biorefinery processes, and the full chain of biogas and green engineering. He has authored more than 300 scientific articles. His current research interests include renewable energy, sustainability, and green jobs for all. He was a member on the invitation with various capacities in the committee for over 500 various international conferences and organizer of international conferences, workshops, and training programs in Europe, Central Asia, and China.



OM PRAKASH MAHELA (Senior Member, IEEE) received the B.E. degree from the College of Technology and Engineering, Udaipur, India, in 2002, the M.Tech. degree from Jagannath University, Jaipur, India, in 2013, and the Ph.D. degree from IIT Jodhpur, Jodhpur, India, in 2018, all in electrical engineering. From 2002 to 2004, he was an Assistant Professor with the Rajasthan Institute of Engineering and Technology, Jaipur. From 2004 to 2014, he was a Junior Engineer with the

Rajasthan Rajya Vidyut Prasaran Nigam Ltd., India, and an Assistant Engineer, since July 2014. He has authored more than 130 research articles and book chapters. His research interests include power quality, power system planning, grid integration of renewable energy sources, FACTS devices, transmission line protection, and condition monitoring. He was a recipient of the University rank certificate, in 2002, the Gold Medal, in 2013, the Best Research Paper Award, in 2018, and the C.V. Raman Gold Medal, in 2019.



PALANISAMY KALIANNAN (Senior Member, IEEE) received the bachelor's degree in electrical engineering from the KSR College of Technology, India, in 2000, the master's degree (Hons.) in applied electronics from the Coimbatore Institute of Technology, India, in 2004, and the Ph.D. degree in electrical engineering from the Vellore Institute of Technology, Vellore, India, in 2013.

He has been an Associate Professor of the Energy and Power Electronics Division, Vellore Institute of Technology, since 2007. He has authored over 86 scientific articles in refereed conference proceedings and international journals in the field of renewable energy, battery energy storage, multilevel converters, and power quality. He is a certified Energy Auditor by the Bureau of Energy Efficiency, Government of India. He has taken up various consultancy projects in energy efficiency and power quality improvement.

• • •